





High performance for building, low impact for the environment.

BE part of a big Group.

We were founded in 2007 as a division of the **Abrasivi Adria** brand: A **100% Italian**, leading group in the abrasives industry, with sales offices currently in Italy and abroad.

With 4 dedicated operations facilities, our production department now covers **20,000 m²**.

DO state-of-the-art jobs.

A quality construction doesn't merely depend on the design and choice of materials, but also the **products used to ensure a workmanlike and long-lasting result**. We are specialised in the formulation and production of substrate preparations, substrates, screeds, primers, waterproofing agents, cementitious adhesives, cementitious and epoxy grouts, wood laying adhesives, rising damp and concrete repair systems. Our solutions are designed for use with marble, granite, porcelain stoneware, ceramics and many other construction materials.

RESPECT the environment: a promise in every product.

Our research laboratories produce increasingly green products, and our meticulous supplier qualification process leads to partnerships based on a shared commitment to sustainability. We offer materials that comply with the **LEED protocol and HD dust-proof technology**.

Our cementitious adhesives are **low in volatile organic substances**.

ASSISTANCE for our customers is part of our quality strategy.

Not just excellent products, but also an excellent service. Our customers can rely on a **highly qualified technical team** trained directly in-house.



INFOGRAPHICS LEGEND



TEMPERATURE OF USE



COVERAGE



WEIGHT



PACKAGE



STORAGE



WIDTH



WAIT TIME/
POT LIFE



CURING TIME



LIGHT FOOT TRAFFIC/
JOINTS



THICKNESS



OUTDOOR_	07
LEVELLING AGENTS FOR SCREEDS_	11
WATERPROOFING AGENTS_	27
GLUES AND LATEXES FOR ADHESIVES_	37
GROUTS AND SEALANTS_	51
REPAIR AGENTS_	63
REPAIRS AND CONCRETE_	67
WOOD LAYING_	73
PROTECTION AND MAINTENANCE OF SURFACES_	77
ACCESSORIES_	83

INDEX



KEDY SAND HD_08

KEDY SAND EASY_08

SIGILSAND_09

KEDIL DESIGN PLUS_09

SIGILBLOCK_09

OUTDOOR

KEDY SAND HD



KEDY SAND HD is a polymeric sand with calibrated particle size produced with HD technology, used to grout pavers, porphyry and sanipietrini. The product is applied using the same technique as traditional sand for grouting paving, except that in applying water, once KEDY SAND HD hardens it becomes very solid and sets between the joints of the paving. This offers several benefits including: keeping the flooring in place, preventing the growth of grass, damage caused by insects and erosion resulting from climatic conditions.

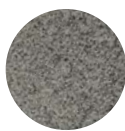

Grey



Beige

DATA MEASURED at +23°C and 50% humidity in the absence of ventilation. This may vary according to the specific site conditions such as temperature, ventilation, absorbency of the substrate and the covering materials. The images contained in this catalogue are for illustrative purposes only.

CHARACTERISTICS



From 35°C to 8°C



Narrow joints: 3.5 Kg/m² approx.
Wide joints: 8 Kg/m² approx.



24 hours



24 months in a dry place and in the original packaging supplied by us, at temperatures between 10°C/30°C.

PRODUCT SPECIFICATIONS

CODE	08050902	08050901
COLOUR	Grey	Beige
PACKAGE	25 Kg bag	25 Kg bag
PALLET	1.500 Kg	1.500 Kg

KEDY SAND EASY



KEDY SAND EASY is a polymeric sand with calibrated particle size for grouting pavers. The product is applied using the same technique as traditional sand for grouting paving, except in the application of water. Once KEDY SAND EASY hardens it becomes very solid and sets between the joints of the paving. This offers several benefits including: keeping the paving in place, preventing the growth of grass, damage caused by insects and erosion resulting from climatic conditions, preventing stains and avoiding efflorescence. The product is easy to apply and clean. It can set even at temperatures below 3°C and resists salt.



Grey



Beige

DATA MEASURED at +23°C and 50% humidity in the absence of ventilation. This may vary according to the specific site conditions such as temperature, ventilation, absorbency of the substrate and the covering materials. The images contained in this catalogue are for illustrative purposes only.

CHARACTERISTICS



From 35°C to 1°C



Narrow joints: 3.5 Kg/m² approx.
Wide joints: 8 Kg/m² approx.



24 hours.



24 months in a dry place and in the original packaging supplied by us, at temperatures between 10°C/30°C.

PRODUCT SPECIFICATIONS

CODE	08050918	08050919
COLOUR	Grey	Beige
PACKAGE	25 Kg bag	25 Kg bag
PALLET	1.500 Kg	1.500 Kg

SIGILSAND



Acrylic resin solvent mixture to be applied on grouted flooring both with normal sand and with mortar with polymeric sand, to secure and strengthen the sand into the joints. Also ideal as a primer for cementitious screeds with a tendency to flake. Also usable on surfaces grouted with Kedy Sand for driveway paving.

DATA MEASURED at + 23°C and 50% humidity in the absence of ventilation. This may vary according to the specific site conditions such as temperature, ventilation, absorbency of the substrate and the covering materials. The images contained in this catalogue are for illustrative purposes only.

CHARACTERISTICS



10 - 20 m²/l



24 months in a dry place and in the original packaging supplied by us, at temperatures between 10°C/30°C.

PRODUCT SPECIFICATIONS

CODE	08050165
PACKAGE	Bucket 15 Kg

KEDIL DESIGN PLUS



One-component aliphatic polyurethane resin for outdoor draining floors, for pebble stones or ornamental paving. Resistant to UV rays, suitable for vehicle traffic, hardens in 24h.

DATA MEASURED at + 23°C and 50% humidity in the absence of ventilation. This may vary according to the specific site conditions such as temperature, ventilation, absorbency of the substrate and the covering materials. The images contained in this catalogue are for illustrative purposes only.

CHARACTERISTICS



1.5 kg per 25 kg of grit



12 months in a dry place and in the packaging provided by us, at temperatures in the range of 10°C/30°C.

PRODUCT SPECIFICATIONS

CODE	08050897
COLOUR	Transparent
PACKAGE	Bag 1.5 Kg
PALLET	Box 4 pieces

SIGILBLOCK



Binder formulated with special resins for grouting porphyry cubes, excellent resistance, draining and quick-drying. Transparent colour.

DATA MEASURED at + 23°C and 50% humidity in the absence of ventilation. This may vary according to the specific site conditions such as temperature, ventilation, absorbency of the substrate and the covering materials. The images contained in this catalogue are for illustrative purposes only.

CHARACTERISTICS



~1kg per m²



24 months in a dry place and in the original packaging supplied by us, at temperatures between 10°C/30°C.

PRODUCT SPECIFICATIONS

CODE	08050170
PACKAGE	Bucket 15 Kg



KEDYCEM MIX_12
MST 14 MIX_12
KEDIFLOW_13
RAPCEM_13
AUTOLEVEL N_14
AUTOLEVEL 2.10_14
AUTOLEVEL 3.30_15
AUTOLEVEL F 3.60_15
KERASOCEM_16
KERASO_16
KERASO LG_17
KERASO SW_17
KERASO XL_18
KERASO F30_18
REPOX_20
APPREX G_20
PRIMER 205_21
ACRYL STRONG_21
STRONG_22
REMOVE_22
FINAL CLEAN_23
ANTIGELO H.T._23
FIBER P2_24
FIBER KD_24

LEVELLING AGENTS
FOR SCREEDS

KEDYCEM MIX





Premixed ready to use for preparing fast hydration and controlled shrinkage screeds from 3 to 8 cm thick. For indoor and outdoor use. Particularly recommended for the installation of ceramic tiles (after 24 hours), stone materials (after 48 hours) and wood and resilient products (after 4 days) using adhesives. Ideal for screeds that need to be coated with cementitious waterproofing products, for heating screeds and high-traffic areas, such as shopping centres, stations and airports etc.



DATA MEASURED at +23°C and 50% humidity in the absence of ventilation. This may vary according to the specific site conditions such as temperature, ventilation, absorptivity of the substrate and the covering materials. The images contained in this catalogue are for illustrative purposes only.

CHARACTERISTICS

-  16 - 18 kg/m² x cm of thickness
-  60 minutes
-  12 months in a dry place and in the original packaging supplied by us.

PRODUCT SPECIFICATIONS

CODE	08020040
COLOUR	Grey
PACKAGE	25 Kg bag
PALLET	1.400 Kg

MST 14 MIX





Premixed, ready-to-use; composed of cement and selected sands, designed to improve workability and ease of application. Controlled shrinkage screed suitable for thicknesses of between 3 and 6 cm. Suitable for indoor and outdoor use. Particularly recommended for fixing ceramic tiles using adhesives (after 24-36 h) and for screeds that need to be coated with waterproofing products.



DATA MEASURED at +23°C and 50% humidity in the absence of ventilation. This may vary according to the specific site conditions such as temperature, ventilation, absorptivity of the substrate and the covering materials. The images contained in this catalogue are for illustrative purposes only.

CHARACTERISTICS

-  16-18 kg/m² x cm of thickness
-  60 minutes
-  12 months in a dry place and in the original packaging supplied by us.

PRODUCT SPECIFICATIONS

CODE	08020025
COLOUR	Grey
PACKAGE	25 Kg bag
PALLET	1.400 Kg

KEDILFLOW



Accelerating thinning additive for screeds and concrete, industrial floors. Increases the mechanical strength and thermal conductivity of the structure.

CHARACTERISTICS



1.0 - 1.5 % on cement.



12 months in a dry place and in the original packaging supplied by us.

PRODUCT SPECIFICATIONS

CODE	08020125
COLOUR	Straw
PACKAGE	Jerrycan 25 Kg
PALLET	600 Kg

DATA MEASURED at + 23°C and 50% humidity in the absence of ventilation. This may vary according to the specific site conditions such as temperature, ventilation, absorbency of the substrate and the covering materials. The images contained in this catalogue are for illustrative purposes only.

RAPCEM



Fast setting hydraulic mortar for the installation of electrical boxes and conduits, wood or metal frames. Suitable for the repair of small areas of brickwork, forming edges, steps or various types of cement products and for sealing small water leaks from concrete pipes and tanks.

CHARACTERISTICS



1.5 - 1.8 Kg/m² x mm of thickness



2 minutes



12 months in a dry place and in the original packaging supplied by us.

PRODUCT SPECIFICATIONS

CODE	08020235	08020230
COLOUR	Grey	Grey
PACKAGE	Box 4x5 Kg	25 Kg bag
PALLET	360	1.500 Kg

DATA MEASURED at + 23°C and 50% humidity in the absence of ventilation. This may vary according to the specific site conditions such as temperature, ventilation, absorbency of the substrate and the covering materials. The images contained in this catalogue are for illustrative purposes only.

AUTOLEVEL N



High-performance normal-setting self-levelling compound for layers from 1 to 10 mm for indoor floors, to level and correct the unevenness of new or existing cementitious substrates, provided they are not subject to rising damp. AUTOLEVEL N is a cementitious smoothing compound used to make subfloors smooth and ready to receive any type of floor covering. It can also be used in high-traffic and high loads areas. Ideal for levelling subfloors prior to the installation of moisture sensitive flooring such as wood, rubber, PVC, natural or reconstituted stone.



DATA MEASURED at +23°C and 50% humidity in the absence of ventilation. This may vary according to the specific site conditions such as temperature, ventilation, absorptency of the substrate and the covering materials. The images contained in this catalogue are for illustrative purposes only.

CHARACTERISTICS

-  16-18 kg/m² x cm of thickness
-  60 minutes
-  12 months in a dry place and in the original packaging supplied by us.

PRODUCT SPECIFICATIONS

CODE	08020055
COLOUR	White
PACKAGE	25 Kg bag
PALLET	1.350 Kg

AUTOLEVEL 2.10







High-performance self-levelling compound for layers from 2 to 10 mm thick. Quick-setting with rapid hardening for both **indoor and outdoor flooring**. Suitable for levelling and evening out defects of new or existing cementitious subfloors, provided they are not subject to rising damp. AUTOLEVEL 2.10 is a cementitious smoothing compound used to smooth substrates and prepare them to receive any type of floor covering. It can also be used in high-traffic and high loads areas. Ideal for levelling subfloors prior to the installation of moisture sensitive flooring such as wood, rubber, PVC, natural or reconstituted stone.



DATA MEASURED at +23°C and 50% humidity in the absence of ventilation. This may vary according to the specific site conditions such as temperature, ventilation, absorptency of the substrate and the covering materials. The images contained in this catalogue are for illustrative purposes only.

CHARACTERISTICS

-  1.7 Kg/m² x mm of thickness.
-  25 minutes
-  12 months in a dry place and in the original packaging supplied by us.
-  3 hours

PRODUCT SPECIFICATIONS

CODE	08020050
COLOUR	Grey
PACKAGE	25 Kg bag
PALLET	1.500 Kg

AUTOLEVEL 3.30







High-performance self-levelling compound for layers from 3 to 30 mm thick. Quick-setting with rapid hardening for both **indoor and outdoor flooring**. Suitable for levelling and evening out defects of new or existing cementitious subfloors, provided they are not subject to rising damp. AUTOLEVEL 3.30 is a cementitious smoothing compound used to smooth substrates and prepare them to receive any type of floor covering. It can also be used in high-traffic and high loads areas. Ideal for levelling subfloors prior to the installation of moisture sensitive flooring such as wood, rubber, PVC, natural or reconstituted stone.



DATA MEASURED at +23°C and 50% humidity in the absence of ventilation. This may vary according to the specific site conditions such as temperature, ventilation, absorbency of the substrate and the covering materials. The images contained in this catalogue are for illustrative purposes only.

CHARACTERISTICS

-  1.7 kg/m² x mm of thickness
-  25 minutes
-  12 months in a dry place and in the original packaging supplied by us.
-  3 hours

PRODUCT SPECIFICATIONS

CODE	08020060
COLOUR	Grey
PACKAGE	25 Kg bag
PALLET	1.500 Kg

AUTOLEVEL F 3.60







High-performance self-levelling compound, fibre-reinforced, conductive, for layers from 3 to 60 mm, quick-setting with rapid hardening and controlled shrinkage, for indoor and outdoor flooring, to level and correct unevenness of substrates also subject to high stress where a high level of elasticity is required (including on pre-existing wooden flooring) prior to laying ceramic tiles, wood, resilient materials, natural stone, marble and granite reconstituted in cement or resin. **Ideal for heating floors thanks to its high conductivity due to the nature of the fibres, resulting in domestic heating energy savings.**



DATA MEASURED at +23°C and 50% humidity in the absence of ventilation. This may vary according to the specific site conditions such as temperature, ventilation, absorbency of the substrate and the covering materials. The images contained in this catalogue are for illustrative purposes only.

CHARACTERISTICS

-  1.7 kg/m² x mm of thickness
-  25 minutes
-  12 months in a dry place and in the original packaging supplied by us.
-  3 hours

PRODUCT SPECIFICATIONS

CODE	08020065
COLOUR	Grey
PACKAGE	25 Kg bag
PALLET	1.500 Kg

KERASOCEM



Extra white levelling compound for standard finish, for wall and ceiling, indoors and outdoors, for thicknesses up to 3 mm. Particularly suitable for ultra smooth finishes of traditional or premixed plasters and plasterboard panels.

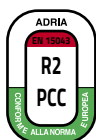

DATA MEASURED at +23°C and 50% humidity in the absence of ventilation. This may vary according to the specific site conditions such as temperature, ventilation, absorptency of the substrate and the covering materials. The images contained in this catalogue are for illustrative purposes only.

CHARACTERISTICS



1.4 kg/m² x mm of thickness



8 hours



12 months in a dry place and in the original packaging supplied by us.

PRODUCT SPECIFICATIONS

CODE	08020240
COLOUR	White
PACKAGE	Bag 20 Kg
PALLET	1.200 Kg

KERASO



Fibre-reinforced thixotropic cementitious levelling compound to prepare substrates for indoor and outdoor floors and walls. It can be applied to a thickness of between 2 and 10 mm. Suitable for smoothing cementitious substrates provided they are solid and clean such as plasters and screeds, concrete walls and floors, masonry etc. Adheres without any primer even to existing acrylic coverings. Suitable for repairing or levelling steps, depressions and holes in screeds.

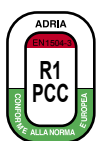

DATA MEASURED at +23°C and 50% humidity in the absence of ventilation. This may vary according to the specific site conditions such as temperature, ventilation, absorptency of the substrate and the covering materials. The images contained in this catalogue are for illustrative purposes only.

CHARACTERISTICS



1.6 Kg/m² x mm of thickness.



6 hours



12 months in a dry place and in the original packaging supplied by us.

PRODUCT SPECIFICATIONS

CODE	08020070	08020080
COLOUR	Grey	White
PACKAGE	25 Kg bag	25 Kg bag
PALLET	1.500 Kg	1.500 Kg



KERASO LG



Hydrated lime-based water-repellent finish plaster, for indoor and outdoor use, with thickness of 5 mm per coat.

DATA MEASURED at +23°C and 50% humidity in the absence of ventilation. This may vary according to the specific site conditions such as temperature, ventilation, absorbency of the substrate and the covering materials. The images contained in this catalogue are for illustrative purposes only.

CHARACTERISTICS

-  1.6 Kg/m² x mm thickness
-  60 minutes
-  12 months in a dry place and in the original packaging supplied by us.

PRODUCT SPECIFICATIONS

CODE	08020082
COLOUR	White
PACKAGE	25 Kg bag
PALLET	1.500 Kg

KERASO SW



Fibre-reinforced thixotropic cementitious levelling compound, water-repellent, extra-white, for application on walls and floors to a thickness between 2 and 20 mm, suitable for levelling concrete walls and floors, excellent workability and finish.



DATA MEASURED at +23°C and 50% humidity in the absence of ventilation. This may vary according to the specific site conditions such as temperature, ventilation, absorbency of the substrate and the covering materials. The images contained in this catalogue are for illustrative purposes only.

CHARACTERISTICS

-  1.7 kg/m² x mm of thickness
-  6 hours
-  12 months in a dry place and in packaging provided by us.

PRODUCT SPECIFICATIONS

CODE	08020085
COLOUR	White
PACKAGE	25 Kg bag
PALLET	1.500 Kg

KERASO XL







Fibre-reinforced thixotropic cementitious levelling compound for layers from 2 to 35 mm thick, high performance. Fast setting and fast hydration for both indoor and outdoor flooring and walls. Suitable for levelling and evening out defects of new or existing cementitious subfloors, also suitable for repairing damaged cementitious areas. It can also be used in high-traffic and high loads areas. Ideal for levelling subfloors prior to the installation of moisture sensitive flooring such as wood, rubber, PVC, natural or reconstituted stone.



DATA MEASURED at +23°C and 50% humidity in the absence of ventilation. This may vary according to the specific site conditions such as temperature, ventilation, absorbency of the substrate and the covering materials. The images contained in this catalogue are for illustrative purposes only.

CHARACTERISTICS

-  1.6 Kg/m² x mm of thickness.
-  40 minutes
-  12 months in a dry place and in the original packaging supplied by us.
-  45 minutes

PRODUCT SPECIFICATIONS

CODE	08020090
COLOUR	Grey
PACKAGE	25 Kg bag
PALLET	1.500 Kg

KERASO F30



Fibre-reinforced thixotropic cementitious levelling compound for the preparation of indoor and outdoor floors and walls. It can be applied to a thickness of between 3 and 30 mm. Suitable for smoothing cementitious substrates provided that they are solid and clean such as cement plasters and screeds, concrete walls and floors, masonry etc. Suitable for repairing or levelling steps, depressions and holes in screeds.



DATA MEASURED at +23°C and 50% humidity in the absence of ventilation. This may vary according to the specific site conditions such as temperature, ventilation, absorbency of the substrate and the covering materials. The images contained in this catalogue are for illustrative purposes only.

CHARACTERISTICS

-  1.6 Kg/m² x mm of thickness.
-  60 minutes
-  12 months in a dry place and in the original packaging supplied by us.

PRODUCT SPECIFICATIONS

CODE	08020100
COLOUR	Grey
PACKAGE	25 Kg bag
PALLET	1.500 Kg

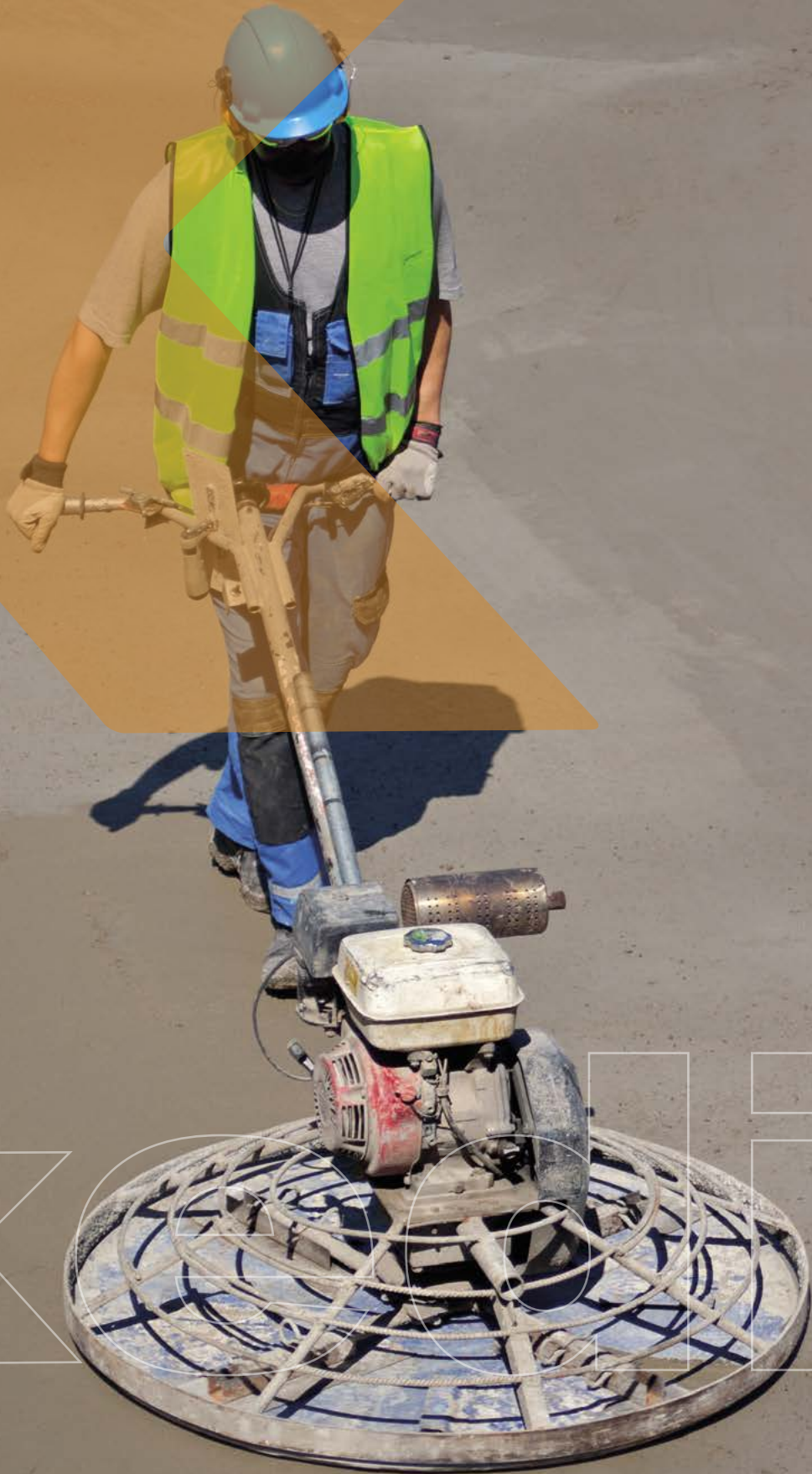

REPOX

Two-component, pourable epoxy resin, ideal for construction joints and monolithic sealing of cracks in cementitious substrates, for fixing iron rods or plates to concrete.



DATA MEASURED at + 23°C and 50% humidity in the absence of ventilation. This may vary according to the specific site conditions such as temperature, ventilation, absorbcency of the substrate and the covering materials. The images contained in this catalogue are for illustrative purposes only.

CHARACTERISTICS



0.8 - 1.7 kg/m² x cm construction joints
100 - 150 g/m: sealing of cracks



50 - 70 minutes



12 months in a dry place and in the packaging provided by us, protected from frost and high temperatures

PRODUCT SPECIFICATIONS

CODE	08020255
COLOUR	White
PACKAGE	Bucket 2Kg
PALLET	160 Kg

APPREX G



Aqueous dispersion of synthetic resins for preparing gypsum and anhydrite based substrates. **APPREX G** penetrates into the pores of the materials, closing them and forming a very thin film that prevents chemical contact between the adhesive and the substrate. When **APPREX G** is applied to very absorbent substrates or surfaces with different absorbcency coefficients (such as lime-based plasters, cement lime mortars, absorbent cementitious substrates etc.) it regulates and evens out the degree of absorption.

DATA MEASURED at + 23°C and 50% humidity in the absence of ventilation. This may vary according to the specific site conditions such as temperature, ventilation, absorbcency of the substrate and the covering materials. The images contained in this catalogue are for illustrative purposes only.

CHARACTERISTICS



100 - 150 g/m²



2 hours



12 months in a dry place and in the packaging provided by us, protected from frost and high temperatures

PRODUCT SPECIFICATIONS



CODE	08020115	08020110	08020120
COLOUR	Sea green	Sea green	Sea green
PACKAGE	Bottle 1 Kg	Jerrycan 5 Kg	Jerrycan 25 Kg
PALLET	384 Kg	480 Kg	600 Kg

PRIMER 205



One-component adhesion promoter formulated with resins in aqueous dispersion, free of solvents and mineral fillers. Suitable for smooth and low-absorbent substrates, to be used before the application of levelling compounds and cementitious adhesives. For indoor use only.

CHARACTERISTICS

-  100 - 150 g/m² depending on the substrate
-  4 hours
-  12 months in a dry place and in the packaging provided by us, protected against frost and high temperatures

PRODUCT SPECIFICATIONS

CODE	08020260	08020265
COLOUR	Green	Green
PACKAGE	Bottle 1 Kg	Jerrycan 5 Kg
PALLET	384 Kg	480 Kg

DATA MEASURED at +23°C and 50% humidity in the absence of ventilation. This may vary according to the specific site conditions such as temperature, ventilation, absorbency of the substrate and the covering materials. The images contained in this catalogue are for illustrative purposes only.

ACRYL STRONG



Water-based, high-penetration consolidating primer formulated with acrylic copolymers in aqueous dispersion with very fine particles suitable for all wall surfaces. The application of **ACRYL STRONG** consolidates and evens out absorption.

CHARACTERISTICS

-  300 - 1000 g/m²
-  50 - 70 minutes
-  12 months in a dry place and in the packaging provided by us, protected from frost and high temperatures

PRODUCT SPECIFICATIONS

CODE	08020155
COLOUR	Transparent
PACKAGE	Jerrycan 5 Kg
PALLET	480 Kg

DATA MEASURED at + 23°C and 50% humidity in the absence of ventilation. This may vary according to the specific site conditions such as temperature, ventilation, absorbency of the substrate and the covering materials. The images contained in this catalogue are for illustrative purposes only.

STRONG



Consolidating primer for cement screeds and substrates that have a tendency to crumble. STRONG penetrates deeply, consolidates and gives higher strength to the substrate. Do not apply so much that the substrate becomes saturated. It is free from organic solvents, unpleasant odours and does not release substances that are harmful to health.

DATA MEASURED at +23°C and 50% humidity in the absence of ventilation. This may vary according to the specific site conditions such as temperature, ventilation, absorbcency of the substrate and the covering materials. The images contained in this catalogue are for illustrative purposes only.

CHARACTERISTICS



300 - 1000 g/m²



50 - 70 minutes



12 months in a dry place and in the packaging provided by us, protected from frost and high temperatures

PRODUCT SPECIFICATIONS

CODE	08020150	08020160
COLOUR	Transparent	Transparent
PACKAGE	Jerrycan 5 Kg	Jerrycan 25 Kg
PALLET	480 Kg	600 Kg

REMOVE



Alkaline cleaning agent suitable for removing oil, grease, wax and atmospheric pollutants from any type of surface. Essential before an overlay on existing flooring.

DATA MEASURED at +23°C and 50% humidity in the absence of ventilation. This may vary according to the specific site conditions such as temperature, ventilation, absorbcency of the substrate and the covering materials. The images contained in this catalogue are for illustrative purposes only.

CHARACTERISTICS



100 - 200 g/m²



15 minutes



12 months in a dry place and in the packaging provided by us, protected against frost and high temperatures

PRODUCT SPECIFICATIONS

CODE	08020165	08020170
COLOUR	Transparent	Transparent
PACKAGE	Bottle 1 Kg	Jerrycan 5 Kg
PALLET	384 Kg	480 Kg

FINAL CLEAN



Cleaner formulated with buffered acid mixtures to remove cement residue from ceramic surfaces. Can be used as a final cleaner after grouting.

CHARACTERISTICS



100 - 200 g/m²
depending on the substrate



Wait time before
rinsing: 5 minutes



12 months in a dry place and in the
packaging provided by us, protected
against frost and high temperatures

PRODUCT SPECIFICATIONS

CODE	08020185	08020190
COLOUR	Transparent	Transparent
PACKAGE	Bottle 1 Kg	Jerrycan 5 Kg
PALLET	384 Kg	480 Kg

DATA MEASURED at + 23°C and 50% humidity in the absence of ventilation. This may vary according to the specific site conditions such as temperature, ventilation, absorbency of the substrate and the covering materials. The images contained in this catalogue are for illustrative purposes only.

ANTIFREEZE H.T.



Antifreeze agent for cementitious mortars and adhesives. By speeding up the hardening rate of the cement, it generates the heat necessary to prevent the water in the mix from freezing. For use from between -5 °C and -10 °C.

CHARACTERISTICS



125 g on 25 kg bag



12 months in a
dry place and in packaging
provided by us.

PRODUCT SPECIFICATIONS

CODE	08020220
COLOUR	White
PACKAGE	Box 5 x 3 Kg
PALLET	270 Kg

DATA MEASURED at + 23°C and 50% humidity in the absence of ventilation. This may vary according to the specific site conditions such as temperature, ventilation, absorbency of the substrate and the covering materials. The images contained in this catalogue are for illustrative purposes only.

FIBER P2



KEDIL FIBER P2 is a polymer-fibre in extruded polypropylene (PP) with oriented fibres for the reinforcement of traditional cement screeds. The sinusoidal shape and surface marked by small depressions allows excellent adhesion to the cement matrix, ensuring a high increase in the tensile strength and ductility of the mix. The dimensions of the KEDIL FIBER P2 fibre have been designed for even distribution within the mix without affecting workability or interfering with mechanical or pneumatic pumping systems.

DATA MEASURED at +23°C and 50% humidity in the absence of ventilation. This may vary according to the specific site conditions such as temperature, ventilation, absorptivity of the substrate and the covering materials. The images contained in this catalogue are for illustrative purposes only.

CHARACTERISTICS



1 - 5 Kg/m³

PRODUCT SPECIFICATIONS

CODE	08020217	08020221
COLOUR	Coarse white	Fine white
PACKAGE	Bag 5 Kg	Bag 4 Kg
PALLET	250 Kg	200 Kg

FIBER KD



Synthetic fibre for concrete products. Ideal for preventing shrinkage cracks during hardening. The fibres improve the quality of the surface by reducing porosity and increasing abrasion and impact resistance.

FIBER KD grey is ideal for cement screeds.

DATA MEASURED at + 23°C and 50% humidity in the absence of ventilation. This may vary according to the specific site conditions such as temperature, ventilation, absorptivity of the substrate and the covering materials. The images contained in this catalogue are for illustrative purposes only.

PRODUCT SPECIFICATIONS

CODE	08020211
COLOUR	Grey
PACKAGE	Bag 5 Kg
PALLET	500 Kg





KEDILASTIC 1_29
KEDILASTIC_29
OSMOTEK_30
KEDY ROOF_30
ISOLFLEX_30
KEDY bit-ONE_31
PRIMERFLEX_31
BDL 100 S_32
BDL 120_32
BDL 140_32
BDL TEX NET PLUS_33
KEDIL NET_33
TEX NET PLUS_33
ISO TEX_34
TEX DESOLARIZZANTE_34
POLYTEX_34

WATERPROOFING
MATERIALS



KEDILASTIC 1



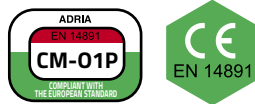

One-component, fibre-reinforced, waterproofing and anti-carbonation cementitious mortar with average flexibility. Can be applied to concrete and cement plasters and screeds. Suitable for use in swimming pools, tanks, balconies, terraces, bathrooms and showers. It forms a flexible membrane and can be applied to cementitious substrates or existing wall coverings providing they are clean and firmly anchored to the substrate. Two coats should be applied 3-5 hours apart. To increase the membrane's resistance to cracks in the substrate, a glass fibre mesh must be embedded in the first coat (for surfaces up to 10 square metres, the product can also be used without the mesh).



DATA MEASURED at + 23°C and 50% humidity in the absence of ventilation. This may vary according to the specific site conditions such as temperature, ventilation, absorbency of the substrate and the covering materials. The images contained in this catalogue are for illustrative purposes only.

CHARACTERISTICS

-  1.3 Kg/m² x mm of thickness.
-  50 minutes
-  12 months in a dry place and in the original packaging supplied by us.

PRODUCT SPECIFICATIONS

CODE	08030070
COLOUR	Grey
PACKAGE	20 Kg bag
PALLET	1.200 Kg

KEDILASTIC





A two-component, fibre-reinforced, highly flexible, waterproofing and anti-carbonation cementitious mortar for concrete, cement plasters and screeds. Suitable for use in swimming pools, tanks, balconies, terraces, bathrooms and showers. It forms a flexible membrane and can be applied to cementitious substrates or existing wall coverings providing they are clean and firmly anchored to the substrate. Two coats should be applied 3-5 hours apart. To increase the membrane's resistance to cracks in the substrate, a glass fibre mesh must be embedded in the first coat (for surfaces up to 10 m², the product can also be used without the mesh). Protect from rain and wash-off for at least 48 hours after being applied. Can be overlaid with ceramic tiles after approximately 2-4 days.



DATA MEASURED at + 23°C and 50% humidity in the absence of ventilation. This may vary according to the specific site conditions such as temperature, ventilation, absorbency of the substrate and the covering materials. The images contained in this catalogue are for illustrative purposes only.

CHARACTERISTICS

-  Powder: 1.4 kg/m² x thickness in mm. Latex: 0.5 kg/m² x thickness in mm.
-  50 minutes
-  12 months in a dry place and in the packaging provided by us, protected from frost and high temperatures

CEPRA DRINKING WATER CONTAINMENT = Report N° 111397

PRODUCT SPECIFICATIONS

CODE	08030010	08030020
PACKAGE	Bag 24 Kg	Jerrycan 8 Kg
PALLET	1.440 Kg	480 Kg

OSMOTEK



Ready-mix powdered water-repellent, ready to use with osmotic action on new or existing concrete and cement plasters. It is suitable for rigid waterproofing of basements, cellars, elevator pits, foundations and products for containing water such as tanks, channels, bathtubs and swimming pools. Conforms to EN 1504-2 for the protection of concrete structures, class MC-IR.



DATA MEASURED at +23°C and 50% humidity in the absence of ventilation. This may vary according to the specific site conditions such as temperature, ventilation, absorbency of the substrate and the covering materials. The images contained in this catalogue are for illustrative purposes only.

CHARACTERISTICS



1.4 Kg/m² x mm of thickness.



50 minutes



12 months in a dry place and in the original packaging supplied by us.

PRODUCT SPECIFICATIONS

CODE	08030165
COLOUR	Grey
PACKAGE	25 Kg bag
PALLET	1,500 Kg

KEDY ROOF



One-component, ready-to-use liquid membrane formulated with resins in aqueous dispersion, free of solvents. **KEDY ROOF** is ideal for continuous horizontal waterproofing, resistant to UV rays, trampling and water stagnation. It can be applied by roller or trowel and offers excellent adhesion on various substrates.

To reinforce the insulation, use the **TEX NET fabric** between coats.

DATA MEASURED at +23°C and 50% humidity in the absence of ventilation. This may vary according to the specific site conditions such as temperature, ventilation, absorbency of the substrate and the covering materials. The images contained in this catalogue are for illustrative purposes only.

CHARACTERISTICS



0.7 kg/m² per mm



12 - 24 hours



12 months in a dry place and in the packaging provided by us, protected from frost and high temperatures

PRODUCT SPECIFICATIONS

CODE	08030087/85	08030088/86
COLOUR	White/Manhattan	White/Manhattan
PACKAGE	Bucket 5kg	Bucket 10kg
PALLET	360 Kg	450 Kg

ISOLFLEX



Fast-drying waterproofing liquid membrane for use on indoor and outdoor floors and walls. It can be applied to cement screeds and cement plaster, lightweight cement, wood and plasterboard. It can also be used when overlaying stone or ceramics. Once set, **ISOLFLEX** is very flexible, dry to the touch and capable of withstanding vibration and dilatation. Suitable for waterproofing balconies, terraces, bathrooms and showers. Suitable for encapsulating asbestos cement (after having applied PRIMERFLEX).

DATA MEASURED at +23°C and 50% humidity in the absence of ventilation. This may vary according to the specific site conditions such as temperature, ventilation, absorbency of the substrate and the covering materials. The images contained in this catalogue are for illustrative purposes only.

CHARACTERISTICS



1.5 Kg/m² x mm of thickness.



12 - 24 hours



12 months in a dry place and in the packaging provided by us, protected from frost and high temperatures

PRODUCT SPECIFICATIONS

CODE	08030080
COLOUR	White
PACKAGE	Bucket 5kg
PALLET	450 Kg

KEDY BIT-ONE



One-component, ready-to-use water-based elastomeric bituminous membrane, for indoor and outdoor use, in 5 colours. Resistant to UV rays, water stagnation and trampling



DATA MEASURED at +23°C and 50% humidity in the absence of ventilation. This may vary according to the specific site conditions such as temperature, ventilation, absorbency of the substrate and the covering materials. The images contained in this catalogue are for illustrative purposes only.

CHARACTERISTICS



1.5Kg/m² per mm of thickness per coat.



60 minutes



12 months in a dry place in its original packaging.

PRODUCT SPECIFICATIONS

CODE	COLOUR	PACK/WEIGHT	PALLET
08030073	Tortora	Bucket 5 Kg	360 Kg
08030074	Tortora	Bucket 10 Kg	450 Kg
08030075	Tortora	Bucket 20 Kg	660 kg
08030076	Cotto	Bucket 5 Kg	360 Kg
08030077	Cotto	Bucket 10 Kg	450 Kg
08030078	Cotto	Bucket 20 Kg	660 kg
08030082	Nero	Bucket 5 Kg	360 Kg
08030083	Nero	Bucket 10 Kg	450 Kg
08030084	Nero	Bucket 20 Kg	660 kg
08030090	Grigio	Bucket 5 Kg	360 Kg
08030091	Grigio	Bucket 10 Kg	450 Kg
08030092	Grigio	Bucket 20 Kg	660 kg
08030093	Manhattan	Bucket 5 Kg	360 Kg
08030094	Manhattan	Bucket 10 Kg	450 Kg
08030095	Manhattan	Bucket 20 Kg	660 kg

PRIMERFLEX

One-component primer for cementitious or paste waterproofing membranes. Made of acrylic resins in organic solvent dispersion. Adhesion promoter for Isolflex and Kedilastic products before application to bituminous membranes, existing tiles or vinyl floor coverings. Suitable as an adhesion promoter for any type of adhesive residue. Also ideal as an adhesion promoter for **marble-reinforcing mesh set in epoxy resins.**



DATA MEASURED at + 23°C and 50% humidity in the absence of ventilation. This may vary according to the specific site conditions such as temperature, ventilation, absorbency of the substrate and the covering materials. The images contained in this catalogue are for illustrative purposes only.

CHARACTERISTICS



200-300 g/m² depending on absorption of the substrate.



2 hours



12 months in a dry place in its original packaging.

PRODUCT SPECIFICATIONS

CODE	08030105
COLOUR	White
PACKAGE	Bucket 5 kg
PALLET	400 Kg

BDL 100 S



Two-layer self adhesive sealing strip: visco-elastic and non-woven fabric. To be used before application of the **KEDILASTIC** or **ISOLFLEX** line.

CHARACTERISTICS



100 mm



1 mm

PRODUCT SPECIFICATIONS

CODE	08030110
DESCRIPTION	Strip
PACKAGE	Box 1x10 m
PALLET	250 rolls

BDL 120



Sealant strip for joints and corners. To be positioned whilst applying the first coat of the **KEDILASTIC** or **ISOFLEX** products by pressing the strip onto the layer whilst it is still fresh. Then partially cover it with a second coat.

CHARACTERISTICS



120 mm



0.6 mm

PRODUCT SPECIFICATIONS

CODE	08030120	08030121	08030122	08030123
DESCRIPTION	Strip	Inside corner	Exterior corner	Patch 425x425 mm
PACKAGE	Roll 50 m	Box 25 pieces	Box 25 pieces	Box 10 pieces
PALLET	100 rolls	-	-	-

BDL 140



Reinforcing strip for joints and corners. To be positioned whilst applying the first coat of the **KEDILASTIC** or **ISOFLEX** products by pressing the strip onto the layer whilst it is still fresh. Then partially cover it with a second coat.

CHARACTERISTICS



140 mm



0.4 mm

PRODUCT SPECIFICATIONS

CODE	08030115
DESCRIPTION	Strip
PACKAGE	Roll 50 m
PALLET	60 rolls

BDL TEX NET PLUS



Sealing strip for joints and corners in pressed thread.

To be positioned whilst applying the first coat of the **KEDY ROOF** and **KEDY BIT-ONE LINE** products by pressing the strip onto the layer whilst it is still fresh. Then cover it with the second coat.

CHARACTERISTICS



140 mm



0.3 mm

PRODUCT SPECIFICATIONS

CODE	08030133
DESCRIPTION	Strip
PACKAGE	50 m
PALLET	36 rolls

KEDIL NET

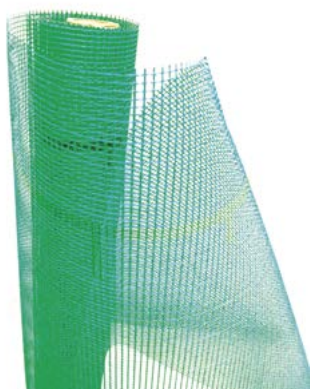

Glass fibre mesh, with alkali-resistant primer to be used as mechanical reinforcement of the **KEDILASTIC** and **ISOLFLEX** line. Also suitable as a reinforcing mesh in exterior insulation and finishing systems, used in combination with **RASOKOLL**. Hole sizes 4x5 mm.

CHARACTERISTICS



155 g/ m² ± 5%



1m²



0.5 mm

PRODUCT SPECIFICATIONS

CODE	08030130
COLOUR	Green
PACKAGE	50m ²
PALLET	33 rolls

TEX NET PLUS



Water-repellent non-woven fabric, elasticized in PP with perforations, to be used as mechanical reinforcement of the **KEDILASTIC**, **KEDY ROOF** and **KEDY BIT-ONE** line. Increases the waterproofness and elasticity of the system, it provides high adhesion waterproofing and deformability on any type of substrate.

CHARACTERISTICS



1m²



0.4 mm

PRODUCT SPECIFICATIONS

CODE	08030134
COLOUR	White
PACKAGE	50m ²
PALLET	30 rolls

ISO TEX



Waterproof membrane, positioned under the layer of tiles, it waterproofs and protects the floor from breakage of the screed and from the migration of moisture. This is due to the two outer layers of polypropylene fabric with one inner layer of polyethylene.

CHARACTERISTICS

1 m²

0.5 mm

PRODUCT SPECIFICATIONS

CODE	08030141
COLOUR	Green
PACKAGE	30m ²
PALLET	100 rolls

TEX DESOLARIZZANTE



Sheeting that allows laying without grouting and expansion joints as it distributes the tension between the parts.

CHARACTERISTICS

1m²

0.7 mm

PRODUCT SPECIFICATIONS

CODE	08030149
COLOUR	White
PACKAGE	50m ²
PALLET	60 rolls

POLYTEX



Waterproof separation fabric with high vapour transfer rate. Suitable for laying large formats on unstable substrates where expansion joints cannot be respected.

CHARACTERISTICS

1m²

0.7 mm

PRODUCT SPECIFICATIONS

CODE	08030146
DESCRIPTION	White
PACKAGE	50m ²
PALLET	60 rolls





GLUES AND LATEXES FOR ADHESIVES

KEDYTILE_38
ADEX_38
KEDYS_39
KEDY STD_39
KEDILFLEX S1_40
KEDY EXTREME_40
KEDY 1S HD_41
KEDYTOP_41
KEDY S2 MONO_42
KEDY S2 EASY_42
KEDYLIGHT_43
SUPER 24_43
FAST_44
FAST MAXI_44
KEDILSTONE_45
KEDILSTONE MAXI_45
SUPERCOVER 1S_46
KEDYCELL_46
RASOKOLL_47
RASOKOLL PLUS_47
KEDILATEX_48
ADHESION_48
KEDYPOX_49
KEDYPOX TIX_49

KEDYTILE



Cementitious adhesive for professional use. Available in white or grey. Used for fixing ceramic tiles and mosaics on indoor floors and walls, on cement screeds and plasters. It can also be applied to gypsum plasters that have been primed with **APPREX G**. Classified as a C1E adhesive (according to EN 12004).



DATA MEASURED at + 23°C and 50% humidity in the absence of ventilation. This may vary according to the specific site conditions such as temperature, ventilation, absorptivity of the substrate and the covering materials. The images contained in this catalogue are for illustrative purposes only.

CHARACTERISTICS



3 - 5 kg/m²



Open time 20 minutes



24 - 36h on floors.
4 - 6h on walls.



12 months in a dry place and in the original packaging supplied by us.

PRODUCT SPECIFICATIONS

CODE	08040430	08040440
COLOUR	Grey	White
PACKAGE	25 Kg bag	25 Kg bag
PALLET	1,500 Kg	1,500 Kg

ADEX



Cementitious adhesive for professional use. Used for fixing ceramic tiles and mosaics intended for indoor and outdoor floors and walls and on cement plasters and screeds. Available in white or grey. After specific priming with **APPREX G**, also on gypsum plasters. Classified as a C1- TE adhesive (according to EN 12004).



DATA MEASURED at + 23°C and 50% humidity in the absence of ventilation. This may vary according to the specific site conditions such as temperature, ventilation, absorptivity of the substrate and the covering materials. The images contained in this catalogue are for illustrative purposes only.

CHARACTERISTICS



3 - 5 kg/m²



Open time 20 minutes



24 - 36h on floors.
4 - 6h on walls.



12 months in a dry place and in the original packaging supplied by us.

PRODUCT SPECIFICATIONS

CODE	08040010	08040020
COLOUR	Grey	White
PACKAGE	25 Kg bag	25 Kg bag
PALLET	1,500 Kg	1,500 Kg

KEDYS



Professional cementitious adhesive, extra colour, for laying tiles indoors and intended for outdoor use, for floors and walls, on cementitious plaster and screeds. After specific priming with **APPREX G**, also on gypsum plasters. Classified as a C1- TE adhesive (according to EN 12004).



DATA MEASURED at + 23°C and 50% humidity in the absence of ventilation. This may vary according to the specific site conditions such as temperature, ventilation, absorbency of the substrate and the covering materials. The images contained in this catalogue are for illustrative purposes only.

CHARACTERISTICS



2 - 5 kg/m²



Open time 20 minutes



24 - 36h on floors.
4 - 6h on walls.



12 months in a dry place and in the original packaging supplied by us.

PRODUCT SPECIFICATIONS

CODE	08040030
COLOUR	White
PACKAGE	25 Kg bag
PALLET	1.500 Kg

KEDY STD



Mixed binder cementitious adhesive for professional use. Used for laying stoneware, all kinds of ceramic and stone materials provided they are stable against humidity. For indoor and outdoor use, on floors and walls, on cement plasters and screeds, on existing flooring and on new underfloor heating screeds. After specific priming with **APPREX G**, also on gypsum plasters. Classified as a C2TE adhesive (according to EN 12004).



DATA MEASURED at + 23°C and 50% humidity in the absence of ventilation. This may vary according to the specific site conditions such as temperature, ventilation, absorbency of the substrate and the covering materials. The images contained in this catalogue are for illustrative purposes only.

CHARACTERISTICS



3 - 5 kg/m²



Open time 20 minutes



24 - 36h on floors.
4 - 6h on walls.



12 months in a dry place and in the original packaging supplied by us.

PRODUCT SPECIFICATIONS

CODE	08040120	08040130
COLOUR	Grey	White
PACKAGE	25 Kg bag	25 Kg bag
PALLET	1,500 Kg	1,500 Kg

KEDILFLEX S1



Thixotropic cementitious adhesive with no vertical slip, extended open time and high polymer content, for professional use, available in white or grey. Suitable for fixing porcelain stoneware tiles, vitreous mosaics and all types of ceramic and stone materials, provided they are moisture stable. **KEDILFLEX S1** can be used on indoor and outdoor floors and walls, on cement plasters and screeds, on top of existing floors, on heating screeds and cellular concrete blocks (interior use only), in high-traffic areas, in swimming pools, on concrete structures (completely cured), as well as on substrates waterproofed with the **KEDILASTIC** or **ISOLFLEX** line. After specific priming with **APPREX G**, it can also be applied to anhydrite screeds, gypsum walls and plasterboard panels. Classified as an S1 adhesive (according to EN 12004 and EN 120002).



DATA MEASURED at + 23 °C and 50% humidity in the absence of ventilation. This may vary according to the specific site conditions such as temperature, ventilation, absorbency of the substrate and the covering materials. The images contained in this catalogue are for illustrative purposes only.

CHARACTERISTICS



3 - 5 kg/m²



Open time 30 minutes



24 - 36h on floors.
4 - 6h on walls.



12 months in a dry place and in the original packaging supplied by us.

PRODUCT SPECIFICATIONS

CODE	08040140	08040150	08040155
COLOUR	Grey	White	White
PACKAGE	25 Kg bag	25 Kg bag	Box 4 x 5 Kg
PALLET	1.500 Kg	1.500 Kg	1.500 Kg

KEDY EXTREME



Cementitious adhesive, extended open time and high polymer content for professional use. Available in white or grey. Used for laying stoneware tiles, all kinds of ceramic and stone material provided it is stable against humidity. Particularly suitable for fixing large-sized tiles even on substrates that are not perfectly levelled. **KEDY EXTREME** can be used on indoor and outdoor floors and walls, on cement plasters and screeds, on top of existing flooring, on heating screeds and cellular concrete blocks (indoor use only), in high-traffic areas, in swimming pools, on concrete structures (provided they are adequately cured), as well as on substrates waterproofed with the **KEDILASTIC** or **ISOLFLEX** line. After specific priming with **APPREX G**, it can also be applied to anhydrite screeds, gypsum walls and plasterboard panels. Classified as a C2TE S1 adhesive (according to EN 12004 and EN 12002).



DATA MEASURED at + 23 °C and 50% humidity in the absence of ventilation. This may vary according to the specific site conditions such as temperature, ventilation, absorbency of the substrate and the covering materials. The images contained in this catalogue are for illustrative purposes only.

CHARACTERISTICS



3 - 5 kg/m²



Open time 30 minutes



24 - 36h on floors.
4 - 6h on walls.



12 months in a dry place and in the original packaging supplied by us.

PRODUCT SPECIFICATIONS



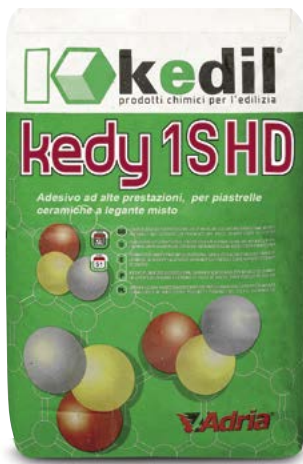

CODE	08040168	08040165
COLOUR	Grey	White
PACKAGE	25 Kg bag	25 Kg bag
PALLET	1.500 Kg	1.500 Kg

KEDY 1S HD



Thixotropic cementitious adhesive with no vertical slip, extended open time and high polymer content, HD dust-proof technology that prevents the formation of dust by up to 95%, for professional use. Available in white or grey. Used for laying porcelain stoneware tiles and all kinds of ceramic and stone materials, provided they are moisture stable. Particularly suitable for fixing large-sized tiles even on substrates that are not perfectly levelled. **KEDY 1S HD** can be used on indoor and outdoor floors and walls, on cement plasters and screeds, on top of existing flooring, on heating screeds and cellular concrete blocks (indoor use only), in high-traffic areas, in swimming pools, on concrete structures (provided they are adequately cured), as well as on substrates waterproofed with the **KEDILASTIC** or **ISOLFLEX** line. Classified as a C2TE S1 adhesive (according to EN 12004 and EN 12002).

CHARACTERISTICS

-  3 - 5 kg/m²
-  Open time 30 minutes
-  24 - 36h on floors.
4 - 6h on walls.
-  12 months in a dry place and in the original packaging supplied by us.

PRODUCT SPECIFICATIONS

CODE	08040170	08040180
COLOUR	Grey	White
PACKAGE	25 Kg bag	25 Kg bag
PALLET	1,500 Kg	1,500 Kg

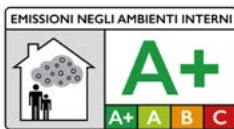





DATA MEASURED at + 23°C and 50% humidity in the absence of ventilation. This may vary according to the specific site conditions such as temperature, ventilation, absorbency of the substrate and the covering materials. The images contained in this catalogue are for illustrative purposes only.

KEDYTOP



Thixotropic cementitious adhesive with no vertical slip, excellent workability, extended open time and high polymer content for professional use. Available in white or grey. Suitable for laying (including thick-bed method) porcelain stoneware tiles and all types of ceramic and stone materials providing they are moisture-stable. Particularly suitable for fixing large-sized tiles even on not perfectly flat substrates (adhesive thickness of up to 15 mm). **KEDYTOP** can be used on indoor and outdoor floors and walls, on cement plasters and screeds, on top of existing flooring, on heating screeds and cellular concrete blocks (indoor use only), in high-traffic areas, in swimming pools, on concrete structures (provided they are adequately cured), as well as on substrates waterproofed with the **KEDILASTIC** or **ISOLFLEX** line. After specific priming with **APPREX G**, it can also be applied to anhydrite screeds, gypsum walls and plasterboard panels. Classified as an C2TE S1 adhesive (according to EN 12004 and EN 12002).

CHARACTERISTICS

-  3 - 5 kg/m²
-  Open time 30 minutes
-  24 - 36h on floors.
4 - 6h on walls.
-  12 months in a dry place and in the original packaging supplied by us.

PRODUCT SPECIFICATIONS

CODE	08040190	08040210
COLOUR	Grey	White
PACKAGE	25 Kg bag	25 Kg bag
PALLET	1,500 Kg	1,500 Kg



DATA MEASURED at + 23°C and 50% humidity in the absence of ventilation. This may vary according to the specific site conditions such as temperature, ventilation, absorbency of the substrate and the covering materials. The images contained in this catalogue are for illustrative purposes only.

KEDY S2 MONO



One-component thixotropic cementitious adhesive with high polymer content, no vertical slip and extended open time, grey or white in colour, for professional use. Suitable for laying, including thick-bed method, of natural stone, mosaics of all kinds, ceramic and porcelain stoneware, as overlay, in swimming pools, on heating screeds subject to heavy traffic, on façades, on flexible bases due to its high elasticity, laying of thin porcelain stoneware also for sizes 150x300cm. Also ideal for laying marble resin and resin-coated marble (stable) with the great advantage of the use of a single component. Adhesive class C2 TE S2



DATA MEASURED at + 23°C and 50% humidity in the absence of ventilation. This may vary according to the specific site conditions such as temperature, ventilation, absorptency of the substrate and the covering materials. The images contained in this catalogue are for illustrative purposes only.

CHARACTERISTICS



3 - 5 kg/m²



Open time 30 minutes



24 - 36h on floors.
4 - 6h on walls.



12 months in a dry place
and in the original packaging supplied
by us.

PRODUCT SPECIFICATIONS

CODE	08040195	08040215
COLOUR	Grey	White
PACKAGE	25 Kg bag	25 Kg bag
PALLET	1,500 Kg	1,500 Kg

KEDY S2 EASY



Single-component cementitious adhesive with high polymer content, self-wetting with extended open time, grey or white in colour, for professional use. Suitable for laying, including thick-bed method, of natural stone, mosaics of all kinds, ceramic and porcelain stoneware, as overlay, in swimming pools, on heating screeds subject to heavy traffic, on façades, on flexible bases due to its high elasticity, laying of thin porcelain stoneware also for sizes 150x300cm. Also ideal for laying marble resin and resin-coated marble (stable) in indoor areas with the great advantage of the use of a single component.



DATA MEASURED at + 23°C and 50% humidity in the absence of ventilation. This may vary according to the specific site conditions such as temperature, ventilation, absorptency of the substrate and the covering materials. The images contained in this catalogue are for illustrative purposes only.

CHARACTERISTICS



3 - 5 kg/m²



Open time 30 minutes



24 - 36h on floors.
4 - 6h on walls.



12 months in a dry place
and in the original packaging supplied
by us.

PRODUCT SPECIFICATIONS





CODE	08040200
COLOUR	Grey
PACKAGE	25 Kg bag
PALLET	1,350 Kg

KEDYLIGHT



Lightweight thixotropic adhesive with high polymer content, no vertical slip and extended open time, suitable for laying large-sized tiles, overlaying, and on underfloor heating screeds. The use of an innovative aggregate allows a 50% higher yield compared to normal adhesives. Suitable for laying large-sized tiles using the back-buttering technique without weighing down the slab.

CHARACTERISTICS

-  1.5 - 2.5 kg/m²
-  Open time 20 minutes
-  24 - 36h on floors. 4 - 6h on walls.
-  12 months in a dry place and in the original packaging supplied by us.

PRODUCT SPECIFICATIONS

CODE	08040161	08040162
COLOUR	Grey	White
PACK.	12.5 Kg bag	Bag 12.5 Kg
PALLET	1000 Kg	1000 Kg







DATA MEASURED at +23°C and 50% humidity in the absence of ventilation. This may vary according to the specific site conditions such as temperature, ventilation, absorbency of the substrate and the covering materials. The images contained in this catalogue are for illustrative purposes only.

SUPER 24



Two component quick setting and hydration cementitious adhesive for professional use. Suitable for installing natural stone, marble and granite, resin- or cement-based agglomerates, ceramic and stoneware. Suitable for indoor and outdoor floors and walls. Its high deformability makes it the ideal adhesive for use with underfloor heating as well as on façades (double-spreading application method), in swimming pools and on top of existing coverings. Particularly suitable for high-traffic areas. It is perfect for glueing reconstituted and dimensionally stable stone. Classified as a C2FTE S2 adhesive (according to EN 12004 and EN 12002).

CHARACTERISTICS

-  3 - 8 kg/m²
-  Open time 20 minutes
-  4 - 6h on floors. 2h on walls
-  12 months in a dry place and in the original packaging supplied by us.
-  45 minutes

PRODUCT SPECIFICATIONS

CODE	08040270	08040280	08040275
COLOUR	Grey	White	Latex
PACKAGE	25 Kg bag	25 Kg bag	Jerrycan 6 Kg
PALLET	1.500 Kg	1.500 Kg	360 Kg



DATA MEASURED at + 23°C and 50% humidity in the absence of ventilation. This may vary according to the specific site conditions such as temperature, ventilation, absorbency of the substrate and the covering materials. The images contained in this catalogue are for illustrative purposes only.

FAST







Thixotropic, quick-setting, cementitious adhesive with no vertical slip and high polymer content for professional use. Suitable for use with medium and large size ceramic and porcelain stoneware tiles and stone materials. Ideal when premises must be ready for use within a limited time. It can be used for high-traffic and high-stress areas. **FAST** can be used on indoor and outdoor floors and walls, on cement plasters and screeds, on top of existing floors, on heating screeds and concrete structures provided they have been adequately cured. After specific priming with **APPREX G**, it can also be applied to anhydrite screeds and gypsum walls. Classified as a C2FTE adhesive (according to EN 12004).



DATA MEASURED at + 23°C and 50% humidity in the absence of ventilation. This may vary according to the specific site conditions such as temperature, ventilation, absorbency of the substrate and the covering materials. The images contained in this catalogue are for illustrative purposes only.

CHARACTERISTICS

-  3 - 5 kg/m²
-  Open time 20 minutes
-  4 - 6h on floors.
2h on walls
-  12 months in a dry place and in the original packaging supplied by us.
-  45 minutes

PRODUCT SPECIFICATIONS

CODE	08040250
COLOUR	Grey
PACKAGE	25 Kg bag
PALLET	1,500 Kg

FAST MAXI







Thixotropic, quick-setting, cementitious adhesive with no vertical slip and high polymer content for professional use. Suitable for medium- to large-sized ceramic and porcelain tiles and for stone materials (as long as moisture-stable). Ideal where the premises must be ready for use in a short time. Can be used in high-traffic, high stress areas. **FAST MAXI** can be used on indoor and outdoor floors and walls, on cement plasters and screeds, on top of existing floors, on heating screeds and concrete structures (provided they have been adequately cured). Particularly suitable for fixing large-sized tiles even on not perfectly flat substrates (adhesive thickness of up to 15 mm). After specific priming with **APPREX G**, it can also be applied to anhydrite screeds and gypsum walls.



DATA MEASURED at + 23°C and 50% humidity in the absence of ventilation. This may vary according to the specific site conditions such as temperature, ventilation, absorbency of the substrate and the covering materials. The images contained in this catalogue are for illustrative purposes only.

CHARACTERISTICS

-  3 - 5 kg/m²
-  Open time 20 minutes
-  4 - 6h on floors.
2h on walls
-  12 months in a dry place and in the original packaging supplied by us.
-  45 minutes

PRODUCT SPECIFICATIONS

CODE	08040260
COLOUR	Grey
PACKAGE	25 Kg bag
PALLET	1,500 Kg

KEDILSTONE



Extra-white, quick-drying, no vertical slip, thixotropic cementitious adhesive with a high polymer content for professional use. Suitable for fixing natural stone and all types of porcelain and ceramic tiles. Suitable for indoor and outdoor floors and walls, on cement plasters and screeds, on top of existing flooring, in high-traffic areas, in swimming pools, cellular concrete blocks (indoor only), on concrete structures (provided they have been adequately cured) as well as on substrates waterproofed with the **KEDILASTIC** or **ISOLFLEX** line. After specific priming with **APPREX G**, it can also be applied to anhydrite screeds, gypsum walls and plasterboard panels. Classified as a C2FTE adhesive (according to EN 12004).



DATA MEASURED at +23°C and 50% humidity in the absence of ventilation. This may vary according to the specific site conditions such as temperature, ventilation, absorbency of the substrate and the covering materials. The images contained in this catalogue are for illustrative purposes only.

CHARACTERISTICS



2 - 5 kg/m²



Open time 20 minutes



4 - 6h on floors.
2h on walls



12 months in a dry place and in the original packaging supplied by us.



45 minutes

PRODUCT SPECIFICATIONS

CODE	08040290
COLOUR	White
PACKAGE	25 Kg bag
PALLET	1.500 Kg

KEDILSTONE MAXI



One-component cementitious adhesive with high polymer content, in white powder, quick-setting, with rapid hardening and no vertical slip, for professional use. Suitable for laying ceramic and porcelain stoneware, including large sizes, natural stone, for overlaying, installation in swimming pools, and in places subject to heavy traffic and high stress. Adhesive complies with classification C2FTE S1 (according to EN 12004) and (EN 12002) adhesive thickness up to 15 mm.



DATA MEASURED at + 23°C and 50% humidity in the absence of ventilation. This may vary according to the specific site conditions such as temperature, ventilation, absorbency of the substrate and the covering materials. The images contained in this catalogue are for illustrative purposes only.

CHARACTERISTICS



3 - 8 kg/m²



Open time 20 minutes



4 - 6h on floors.
2h on walls



12 months in a dry place and in the original packaging supplied by us.



45 minutes

PRODUCT SPECIFICATIONS

CODE	08040300
COLOUR	White
PACKAGE	25 Kg bag
PALLET	1.500 Kg

SUPERCOVER 1S



High-performance, self-wetting, semi-fast setting cementitious adhesive with high flexibility. Particularly recommended for fixing thin, fragile and large-sized materials to floors. Suitable for fixing large-sized ceramic and porcelain tiles and natural stones (provided they are moisture-stable) without the need for double-spreading. After specific priming with **APPREX G**, it is suitable for indoor and outdoor floors and can also be applied to anhydrite screeds.

Ideal for use on existing floors, heating screeds and in high-traffic, high-stress areas. **SUPERCOVER 1S** is also excellent as a levelling compound up to 15 mm. Classified as a C2E S1 adhesive (according to EN 12004 and EN 12002).



DATA MEASURED at +23°C and 50% humidity in the absence of ventilation. This may vary according to the specific site conditions such as temperature, ventilation, absorptency of the substrate and the covering materials. The images contained in this catalogue are for illustrative purposes only.

KEDYCELL



Adhesive mortar for levelling cellular cement blocks, also excellent as a levelling compound. It doesn't create thermal bridges, is sulphate resistant and prevents the formation of salts. For the levelling of cellular cement walls, it is recommended to embed a glass fibre mesh such as **KEDIL NET**.



DATA MEASURED at +23°C and 50% humidity in the absence of ventilation. This may vary according to the specific site conditions such as temperature, ventilation, absorptency of the substrate and the covering materials. The images contained in this catalogue are for illustrative purposes only.

CHARACTERISTICS



3 - 5 kg/m²



Open time 30 minutes



14 - 24h on floors.
2h on walls



12 months in a dry place and in the original packaging supplied by us.

PRODUCT SPECIFICATIONS

CODE	08040240
COLOUR	Grey
PACKAGE	25 Kg bag
PALLET	1,500 Kg

CHARACTERISTICS



Open time 6 hours



12 months in a dry place and in the original packaging supplied by us.

COVERAGE TABLE

Block size cm	kg/m ²
50x25x5 - 62x5x25x5	1,3
50x25x7,5 - 62x5x25x7,5	2,0
50x25x10 - 62x5x25x10	2,5
50x25x15 - 62x5x25x15	3,6

PRODUCT SPECIFICATIONS

CODE	08040090
COLOUR	White
PACKAGE	25 Kg bag
PALLET	1.500 Kg

RASOKOLL



Cement-based levelling adhesive, water-repellent and fibre-reinforced for external insulation systems. Suitable for fixing and levelling insulating panels such as expanded polystyrene, cork and rock wool directly onto render, stone or concrete. Excellent for levelling concrete and prefabricated structures.



DATA MEASURED at +23°C and 50% humidity in the absence of ventilation. This may vary according to the specific site conditions such as temperature, ventilation, absorbency of the substrate and the covering materials. The images contained in this catalogue are for illustrative purposes only.

RASOKOLL PLUS



Cement-based levelling adhesive, water-repellent and fibre-reinforced for external insulation systems. Suitable for fixing and levelling insulating panels such as expanded polystyrene, cork and rock wool directly onto render, stone or concrete. Excellent for levelling concrete and prefabricated structures.



DATA MEASURED at +23°C and 50% humidity in the absence of ventilation. This may vary according to the specific site conditions such as temperature, ventilation, absorbency of the substrate and the covering materials. The images contained in this catalogue are for illustrative purposes only.

CHARACTERISTICS



3 - 6 kg/m²



Open time 6 hours



12 months in a dry place and in the original packaging supplied by us.

PRODUCT SPECIFICATIONS

CODE	08040095	08040105
COLOUR	Grey	White
PACKAGE	25 Kg bag	25 Kg bag
PALLET	1,500 Kg	1,500 Kg

CHARACTERISTICS



3 - 6 kg/m²



Open time 6 hours



12 months in a dry place and in the original packaging supplied by us.

PRODUCT SPECIFICATIONS

CODE	08040098	08040100
COLOUR	Grey	White
PACKAGE	25 Kg bag	25 Kg bag
PALLET	1,500 Kg	1,500 Kg

KEDILATEX



Latex compatible with cement, mortars, adhesives, grouts: improves the product's characteristics. In grouts, 50% dilution with water is recommended.

DATA MEASURED at + 23°C and 50% humidity in the absence of ventilation. This may vary according to the specific site conditions such as temperature, ventilation, absorbency of the substrate and the covering materials. The images contained in this catalogue are for illustrative purposes only.

CHARACTERISTICS



12 months in a dry place and in the original packaging supplied by us.

COVERAGE TABLE

Product	litres per bag
KERASO XL	5.6
KERASO	4.8
KERASO F30	5.5
ADEX	7.5
FAST	6.0
KEDILSTONE	6.0
SIGILCOLOR 1.10	1.3
SIGILCEM 0.4	1.9
SIGILCEM 3.20	5.5

PRODUCT SPECIFICATIONS

CODE	08040325	08040326	08040327	08040328
COLOUR	White	White	White	White
PACKAGE	Bottle 1Kg	Jerrycan 5 Kg	Jerrycan 10 Kg	Jerrycan 25 Kg
PALLET	384 Kg	480 Kg	600 Kg	600 Kg

ADHESION



High-performance, white epoxy-polyurethane adhesive. Its use is universal (indoors and outdoors, on floors and walls) and is particularly suitable for fixing natural stone and marble sensitive to humidity. Adheres to any surface: wood, metal, paint, glass, reinforced concrete, plaster, pre-existing floorings, etc. Due to its elasticity it is optimal for panels and unstable surfaces or in the presence of vibrations. Optimal for masonry kitchens.



DATA MEASURED at + 23°C and 50% humidity in the absence of ventilation. This may vary according to the specific site conditions such as temperature, ventilation, absorbency of the substrate and the covering materials. The images contained in this catalogue are for illustrative purposes only.

CHARACTERISTICS



2 - 3 kg/m²



Open time 2 hours



12h



12 months in a dry place and in the original packaging supplied by us.

PRODUCT SPECIFICATIONS

CODE	08040410	08040420
COLOUR	White	White
PACKAGE	Bucket 5 Kg	Bucket 10 Kg
PALLET	400 Kg	480 Kg

KEDYPOX



Two-component epoxy adhesive with high adhesion, ideal for all substrates, odourless, easy to trowel. **KEDYPOX** is ideal for submerged applications in swimming pools or tanks, excellent in extreme fixing conditions. No vertical slip, for laying large formats on uneven substrates, allowed adhesive thickness of 15 millimetres.



DATA MEASURED at + 23°C and 50% humidity in the absence of ventilation. This may vary according to the specific site conditions such as temperature, ventilation, absorbency of the substrate and the covering materials. The images contained in this catalogue are for illustrative purposes only.

CHARACTERISTICS



2 - 3 kg/m²



Open time 30 minutes



12h



12 months in a dry place and in the original packaging supplied by us.

PRODUCT SPECIFICATIONS

CODE	08040412	08040422
COLOUR	White	White
PACKAGE	Bucket 5 Kg	Bucket 10 Kg
PALLET	450 Kg	500 Kg

KEDYPOX TIX



High performance, white two-component epoxy adhesive, no vertical slip. Its use is universal (indoors and outdoors, on floors and walls) and is particularly suitable for fixing natural stone and marble sensitive to humidity and mesh reinforced. Particularly suitable for swimming pools. Adheres to any surface: wood, metal, paint, glass, reinforced concrete, plaster, pre-existing floorings, etc. Due to its elasticity it is optimal for panels and unstable surfaces or in the presence of vibrations.



DATA MEASURED at + 23°C and 50% humidity in the absence of ventilation. This may vary according to the specific site conditions such as temperature, ventilation, absorbency of the substrate and the covering materials. The images contained in this catalogue are for illustrative purposes only.

CHARACTERISTICS



2 - 3 kg/m²



Open time 30 minutes



12 - 24h on floors
4 - 6h on walls



12 months in a dry place and in the original packaging supplied by us.

PRODUCT SPECIFICATIONS

CODE	08040415	08040425
COLOUR	Beige	Beige
PACKAGE	Bucket 5 Kg	Bucket 10 Kg
PALLET	400 Kg	480 Kg



SIGILCOLOR HF 1.10_52

SIGILCEM 0.4_54

SIGILCEM 3.20_55

SKYLINE ZERO_56

SKYLINE_57

EASY3 FRESH_59

EPODET_60

KEDIFIX_60

KEDISIL N310_61

GROUTINGS AND SEALANTS

SIGILCOLOR HF 1.10



CHARACTERISTICS



24 hours



2 hours

12 months in a dry place
and in the original packaging supplied
by us.

Waterproof cementitious fine-grained sealant with very high workability, velvety finish and easy to clean. Suitable for 1 to 10 mm grouting of ceramic tiles of all types, including porcelain stoneware, natural stone and glass mosaics. Available in a wide range of colours, it has excellent abrasion resistance (AR). Preserves colours over time also thanks to its special additive.

SIGILCOLOR 1.10 is classified as CG2 (according to EN 13888). On exterior façades, in swimming pools, in places with high pedestrian traffic or where cleaning is performed with industrial means it is recommended to use **KEDILATEX**, an elasticising synthetic latex satisfying the requirements of class CG2 (according to EN 13888 and EN 12002), instead of mixing water.

COVERAGE TABLE

Tile (cm)	Grout Kg/m ² joint in mm				
	1	2	3	4	10
2x2x0.4	0.64	1.28	1.92	2.56	6.40
5x5x1x1	0.51	1.02	1.54	2.05	5.12
10x10x1	0.32	0.64	0.96	1.28	3.20
20x20x1	0.16	0.32	0.48	0.64	1.60
30x30x1	0.11	0.21	0.32	0.43	1.07
45x45x1	0.07	0.14	0.21	0.28	0.71
30x60x1	0.08	0.16	0.24	0.32	0.80
60x60x1	0.05	0.11	0.16	0.21	0.53
80x80x1	0.04	0.08	0.12	0.16	0.40
90x90x1	0.04	0.07	0.11	0.14	0.36
100x100x1	0.03	0.06	0.10	0.13	0.32
100x300x1	0.02	0.04	0.06	0.09	0.21
45x90x1	0.05	0.11	0.16	0.21	0.53
20x120x1	0.09	0.19	0.28	0.37	0.93
30x120x1	0.07	0.13	0.20	0.27	0.67
60x120x1	0.04	0.08	0.12	0.16	0.40

COLOURS AVAILABLE:

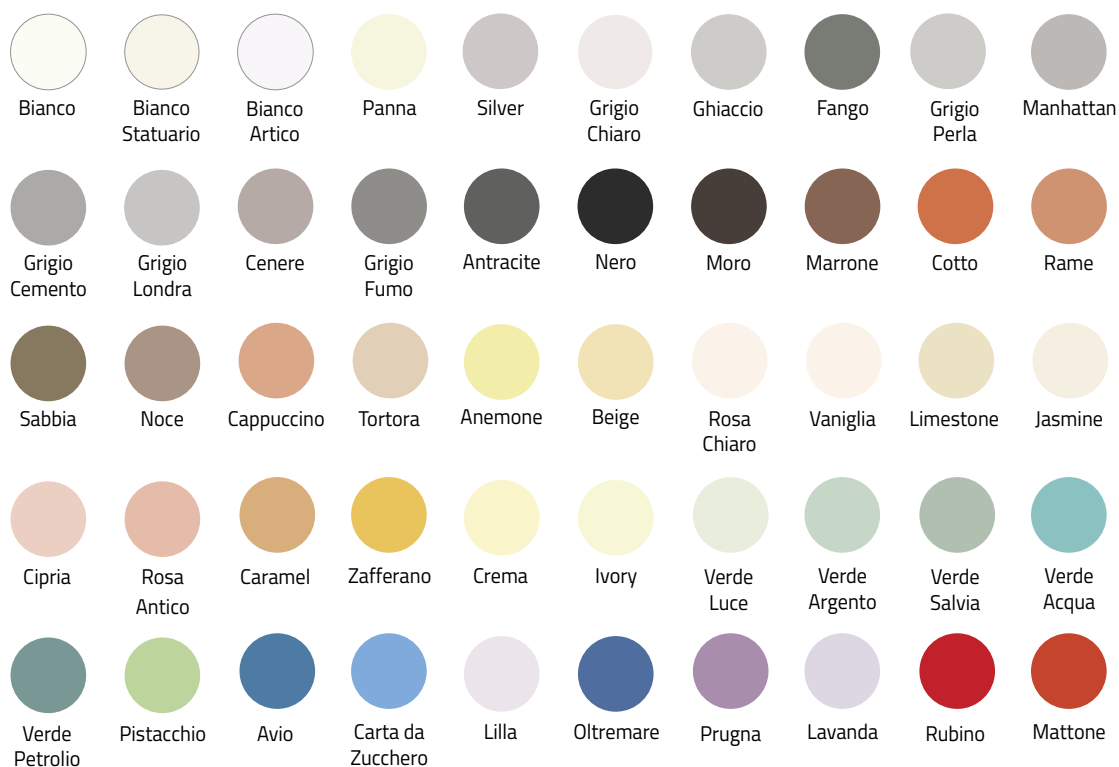

PRODUCT SPECIFICATIONS

CODE	COLOUR	PACK/WEIGHT	PALLET
08050400	100 - Bianco	Box 5x5 Kg	450 Kg
08050401	110 - Bianco Statuario	Box 5x5 Kg	450 Kg
08050403	111 - Bianco Artico	Box 5x5 Kg	450 Kg
08050441	106 - Panna	Box 5x5 Kg	450 Kg
08050406	211 - Silver	Box 5x5 Kg	450 Kg
08050405	201 - Grigio Chiaro	Box 5x5 Kg	450 Kg
08050420	204 - Ghiaccio	Box 5x5 Kg	450 Kg
08050510	206 - Fango	Box 5x5 Kg	450 Kg
08050407	208 - Grigio Perla	Box 5x5 Kg	450 Kg
08050410	202 - Manhattan	Box 5x5 Kg	450 Kg
08050412	202 - Manhattan	25 Kg bag	1500 Kg
08050408	207 - Grigio Cemento	Box 5x5 Kg	450 Kg
08050409	209 - Grigio Londra	Box 5x5 Kg	450 Kg
08050415	203 - Cenere	Box 5x5 Kg	450 Kg
08050417	203 - Cenere	25 Kg bag	1500 Kg
08050413	210 - Grigio Fumo	Box 5x5 Kg	450 Kg
08050425	205 - Antracite	Box 5x5 Kg	450 Kg
08050430	200 - Nero	Box 5x5 Kg	450 Kg
08050485	404 - Moro	Bag 5x5 Kg	450 Kg
08050465	400 - Marrone	Box 5x5 Kg	450 Kg
08050470	401 - Cotto	Box 5x5 Kg	450 Kg
08050472	409 - Rame	Box 5x5 Kg	450 Kg
08050460	302 - Sabbia	Box 5x5 Kg	450 Kg
08050454	305 - Noce	Box 5x5 Kg	450 Kg
08050463	408 - Cappuccino	Box 5x5 Kg	450 Kg
08050530	303 - Tortora	Bag 5x5 Kg	450 Kg

CODE	COLOUR	PACK/WEIGHT	PALLET
08050445	103 - Anemone	Box 5x5 Kg	450 Kg
08050450	300 - Beige	Box 5x5 Kg	450 Kg
08050550	600 - Rosa Chiaro	Box 5x5 Kg	450 Kg
08050442	112 - Vaniglia	Box 5x5 Kg	450 Kg
08050525	105 - Limestone	Box 5x5 Kg	450 Kg
08050435	101 - Jasmine	Box 5x5 Kg	450 Kg
08050551	601 - Cipria	Box 5x5 Kg	450 Kg
08050552	602 - Rosa Antico	Box 5x5 Kg	450 Kg
08050455	301 - Caramel	Box 5x5 Kg	450 Kg
08050446	113 - Zafferano	Box 5x5 Kg	450 Kg
08050444	107 - Crema	Box 5x5 Kg Bag	450 Kg
08050443	108 - Avorio	5x5 Kg	450 Kg
08050492	702 - Verde Luce	Box 5x5 Kg	450 Kg
08050494	704 - Verde Argento	Box 5x5 Kg	450 Kg
08050493	705 - Verde Salvia	Box 5x5 Kg	450 Kg
08050495	701 - Verde Acqua	Box 5x5 Kg	450 Kg
08050496	706 - Verde Petrolio	Box 5x5 Kg Bag	450 Kg
08050507	707 - Pistacchio	5x5 Kg	450 Kg
08050521	801 - Avio	Box 5x5 Kg	450 Kg
08050522	802 - Carta da Zucchero	Box 5x5 Kg	450 Kg
08050536	501 - Lilla	Box 5x5 Kg	450 Kg
08050520	800 - Oltremare	Box 5x5 Kg	450 Kg
08050537	502 - Prugna	Box 5x5 Kg	450 Kg
08050535	500 - Lavanda	Box 5x5 Kg Bag	450 Kg
08050475	402 - Rubino	5x5 Kg	450 Kg
08050473	410 - Mattone	Box 5x5 Kg	450 Kg

SIGILCEM 0.4



Waterproof cementitious fine-grained high workability sealant. Suitable for 0 to 4 mm grouting of ceramic tiles of all types, including porcelain stoneware, natural stone and glass mosaics. Available in different colours, has excellent abrasion resistance (AR).

SIGILCEM 0.4 is classified as CG2 (according to EN 13888). On exterior façades, in swimming pools, in places with high pedestrian traffic or where cleaning is performed with industrial means it is recommended to use **KEDILATEX**, an elasticising synthetic latex satisfying the requirements of class CG2 (according to EN 13888), instead of mixing water.

COVERAGE TABLE

Tile (cm)	Grout Kg/m ² joint in mm				
	1	2	3	4	10
2x2x0.4	0.64	1.28	1.92	2.56	6.40
5x5x1x1	0.51	1.02	1.54	2.05	5.12
10x10x1	0.32	0.64	0.96	1.28	3.20
20x20x1	0.16	0.32	0.48	0.64	1.60
30x30x1	0.11	0.21	0.32	0.43	1.07
45x45x1	0.07	0.14	0.21	0.28	0.71
30x60x1	0.08	0.16	0.24	0.32	0.80
60x60x1	0.05	0.11	0.16	0.21	0.53
80x80x1	0.04	0.08	0.12	0.16	0.40
90x90x1	0.04	0.07	0.11	0.14	0.36
100x100x1	0.03	0.06	0.10	0.13	0.32
100x300x1	0.02	0.04	0.06	0.09	0.21
45x90x1	0.05	0.11	0.16	0.21	0.53
20x120x1	0.09	0.19	0.28	0.37	0.93
30x120x1	0.07	0.13	0.20	0.27	0.67
60x120x1	0.04	0.08	0.12	0.16	0.40

CHARACTERISTICS



24 hours



2 hours



12 months in a dry place and in the original packaging supplied by us.

COLOURS AVAILABLE:



Jasmin



Bianco



Beige



Manhattan



Tortora



Cenere



Rosa Prun



Antracite

PRODUCT SPECIFICATIONS

CODE	COLOUR	PACK/WEIGHT	PALLET
08050010	100 - Bianco	Box 5x5 Kg	450 Kg
08050050	202 - Manhattan	Box 5x5 Kg	450 Kg
08050030	203 - Cenere	Box 5x5 Kg	450 Kg
08050090	205 - Antracite	Box 5x5 Kg	450 Kg
08050060	101 - Jasmin	Box 5x5 Kg	450 Kg
08050070	300 - Beige	Box 5x5 Kg	450 Kg
08050065	303 - Tortora	Box 5x5 Kg	450 Kg
08050095	109 - Rosa Prun	Box 5x5 Kg	450 Kg

DATA MEASURED at +23°C and 50% humidity in the absence of ventilation. This may vary according to the specific site conditions such as temperature, ventilation, absorptivity of the substrate and the covering materials. The images contained in this catalogue are for illustrative purposes only.

SIGILCEM 3.20



CHARACTERISTICS



24 hours



2 hours



12 months in a dry place and in the original packaging supplied by us.

COLOURS AVAILABLE:



Beige



Manhattan



Cenere



Grigio Cemento



Antracite

Cementitious coarse-grained very high workability sealant. Suitable for 3 to 20 mm grouting of ceramic tiles of all types, including porcelain stoneware, natural stone and glass mosaics. Available in different colours, it has very good abrasion resistance (AR) and low water absorption (W). **SIGILCEM 3.20** is classified as CG2 (according to EN 13888).

On exterior façades, in swimming pools, in places with high pedestrian traffic or where cleaning is performed with industrial means it is recommended to use **KEDILATEX**, an elasticising synthetic latex satisfying the requirements of class CG2 (according to EN 13888 and EN 12002), instead of mixing water.

COVERAGE TABLE

Tile (cm)	Grout Kg/m ² joint in mm						
	3	5	8	10	12	15	20
10x10x0.8 - 7.5x15x1	0.62	1.01					
15x15x1 - 12x24x1	0.53	0.86	1.34	1.65			
20x20x1	0.40	0.66	1.03	1.26	1.50		
20x25x1	0.36	0.59	0.93	1.15	1.36	1.66	
20x30x1	0.33	0.55	0.86	1.07	1.26	1.55	2.01
30x30x1	0.27	0.44	0.70	0.86	1.03	1.26	1.65
45x45x1 - 30x90x1	0.22	0.36	0.57	0.70	0.84	1.04	1.36
30x60x1	0.20	0.33	0.53	0.65	0.78	0.96	1.26
60x60x1,2	0.16	0.27	0.43	0.53	0.63	0.79	1.04
60x120x1,2	0.12	0.20	0.32	0.40	0.48	0.59	0.79

PRODUCT SPECIFICATIONS

CODE	COLOUR	PACK/WEIGHT	PALLET
08050120	202 - Manhattan	25 Kg bag	1,500Kg
08050100	203 - Cenere	25 Kg bag	1,500Kg
08050140	205 - Antracite	25 Kg bag	1,500Kg
08050110	300 - Beige	25 Kg bag	1,500Kg
08050125	207 - Grigio Cemento	25 Kg bag	1,500Kg

SKYLINE ZERO



Two-component sealant with very fine recycled glass for non-spaced tile grouting from 0 to 2 mm, indispensable for environments that must remain perfectly hygienic. Particularly suitable due to their technical specifications for the grouting of ceramic, stone, glass materials, including ground and of low thickness. Not suitable for use on porous surfaces. Its pleasant, smooth and shiny appearance, as well as the high level of hygiene guaranteed by the absence of porosity, makes it the ideal choice for grouting in masonry kitchens, bathrooms, wellness centres and swimming pools. Also ideal to repair old damaged grouting without having to remove it. **SKYLINE ZERO** is classified as RG according to EN 13888.

CHARACTERISTICS



24 hours



2 hours



12 months in a dry place and in the original packaging supplied by us.

AVAILABLE COLOURS:*



Jasmin



Bianco



Beige



Manhattan



Nero



Cenere



Antracite

*Certain colours are available only to order

COVERAGE TABLE

Tile (cm)	Groud Kg/m ² joint in mm
	2
2x2x0.4	0.65
5x5x0.8	0.58
10x10x0.8 - 7.5x15x1	0.40
15x15x1-12x24x1	0.33
20x20x1	0.25
20x25x1	0.23
20x30x1	0.21
30x30x1	0.17
45x45x1-30x90x1	0.14
30x60x1	0.13
60x60x1,2	0.10
60x120x1,2	0.08

PRODUCT SPECIFICATIONS

CODE	COLOUR	PACK/WEIGHT	PALLET
08050850	100 - Bianco	Bucket 3 Kg	402 Kg
08050855	202 - Manhattan	Bucket 3 Kg	402 Kg
08050860	203 - Cenere	Bucket 3 Kg	402 Kg
08050865	205 - Antracite	Bucket 3 Kg	402 Kg
08050870	101 - Jasmin	Bucket 3 Kg	402 Kg
08050875	300 - Beige	Bucket 3 Kg	402 Kg
08050880	200 - Nero	Bucket 3 Kg	402 Kg

SKYLINE



Anti-acid two-component epoxy sealant, essential for environments that must remain perfectly hygienic. Available in a wide range of harmonious colours, with a delicate finish, for grouting of between 2 mm and 20 mm for floors and walls of ceramics and natural non-porous stone. Due its pleasant smooth shiny appearance, and the high level of hygiene that is guaranteed by the absence of porosity, it is the ideal choice for grouting in masonry kitchens, bathrooms, wellness centres and swimming pools. Suitable for industrial floors, abattoirs, at milk and cheese production facilities, breweries, etc. because they can be easily washed with acid using industrial methods. Where high resistance to acids and chemicals is required, it can also be used as an R2T class adhesive (according to EN 12004). Prior to commencing plastering operations carry out a test application in an inconspicuous area.

IT is not recommended in Tuscan cotto grouting or for porous surfaces in general. **SKYLINE** is RG classified (according to EN 13888).

COVERAGE TABLE

Tile (cm)	Grout Kg/m ² joint in mm						
	3	5	8	10	12	15	20
2x2x0.4	1.25						
5x5x0.8	0.58	1.33					
10x10x0.8 - 7.5x15x1	0.40	0.95	1.46	1.77			
15x15x1 - 12x24x1	0.33	0.81	1.26	1.54	1.82		
20x20x1	0.25	0.61	0.96	1.19	1.40	1.72	
20x25x1	0.23	0.55	0.87	1.07	1.27	1.56	2.02
20x30x1	0.21	0.51	0.81	1.00	1.18	1.45	1.88
30x30x1	0.17	0.41	0.65	0.81	0.96	1.19	1.54
45x45x1 - 30x90x1	0.14	0.33	0.53	0.66	0.78	0.97	1.27
30x60x1	0.13	0.31	0.49	0.61	0.73	0.90	1.18
60x60x1,2	0.10	0.25	0.40	0.50	0.59	0.74	0.97
60x120x1,2	0.08	0.19	0.30	0.38	0.45	0.56	0.74

CHARACTERISTICS



24 hours



2 hours



12 months in a dry place and in the original packaging supplied by us.

AVAILABLE COLOURS:*



Neutro



Bianco



Manhattan



Antracite



Nero



Jasmine



Beige



Tortora



Crocus



Oltremare



Cenere



Anemone



Moro

*Certain colours are available only to order

PRODUCT SPECIFICATIONS

CODE	COLOUR	PACK/WEIGHT	PALLET
08050671	000 - Neutro	Bucket 3 Kg	402 Kg
08050601	100 - Bianco	Bucket 3 Kg	402 Kg
08050606	202 - Manhattan	Bucket 3 Kg	402 Kg
08050611	203 - Cenere	Bucket 3 Kg	402 Kg
08050616	205 - Antracite	Bucket 3 Kg	402 Kg
08050621	200 - Nero	Bucket 3 Kg	402 Kg
08050626	101 - Jasmin	Bucket 3 Kg	402 Kg
08050631	103 - Anemone	Bucket 3 Kg	402 Kg
08050636	300 - Beige	Bucket 3 Kg	402 Kg
08050641	303 - Tortora	Bucket 3 Kg	402 Kg
08050651	404 - Moro	Bucket 3 Kg	402 Kg
08050656	802 - Crocus	Bucket 3 Kg	402 Kg
08050661	800 - Oltremare	Bucket 3 Kg	402 Kg



EASY3 FRESH



Highly cleanable ceramic epoxy sealant provided in Kit. **EASY3 FRESH** is antacid, indispensable for environments that must remain perfectly hygienic, with a delicate finish, for grouting of between 2 mm and 20 mm for floors and walls of ceramics and natural non-porous stone. This quartzite, coming in different colours and packed in a practical bag, offers the possibility of infinite shades and customizable hues. Due its pleasant smooth shiny appearance, and the high level of hygiene that is guaranteed by the absence of porosity, it is the ideal choice for grouting in masonry kitchens, bathrooms, wellness centres and swimming pools. Suitable for industrial floors, abattoirs, at milk and cheese production facilities, breweries, etc. because they can be easily washed with acid using industrial methods. Where high resistance to acids and chemicals is required, it can also be used as an R2T class adhesive (according to EN 12004). Prior to commencing plastering operations carry out a test application in an inconspicuous area.



CHARACTERISTICS



24 hours



2 hours



12 months in a dry place and in the original packaging supplied by us.

AVAILABLE COLOURS:*



Nero



Antracite



Bruno



Grigio Portland



Ardesia



Grigio Bardiglio



Silver



Grigio Seta



Bianco Ghiaccio



Bianco



Bianco Titanio



Ivory



Travertino



Sabbia



Neutro



Tortora



Grigio Fango



Rosso Ossido



Verde Salvia



Verde Pino



Turchese



Artic Blue



Quarzo Zaffiro

*Certain colours are available only to order

PRODUCT SPECIFICATIONS

CODE	COLOUR	PACK/WEIGHT	PALLET
08050780	-	A Bucket kg.0.475 + B kg.0.125	402 Kg
08050781	Nero	C Bag kg.2.40	402 Kg
08050782	Antracite	C Bag kg.2.40	402 Kg
08050783	Bruno	C Bag kg.2.40	402 Kg
08050784	Grigio Portland	C Bag kg.2.40	402 Kg
08050785	Ardesia	C Bag kg.2.40	402 Kg
08050786	Grigio Bardiglio	C Bag kg.2.40	402 Kg
08050787	Grigio Seta	C Bag kg.2.40	402 Kg
08050788	Silver	C Bag kg.2.40	402 Kg
08050789	Bianco Titanio	C Bag kg.2.40	402 Kg
08050790	Bianco Ghiaccio	C Bag kg.2.40	402 Kg
08050791	Bianco	C Bag kg.2.40	402 Kg

CODE	COLOUR	PACK/WEIGHT	PALLET
08050792	Ivory	C Bag kg.2.40	402 Kg
08050793	Travertino	C Bag kg.2.40	402 Kg
08050794	Sabbia	C Bag kg.2.40	402 Kg
08050795	Neutro	C Bag kg.2.40	402 Kg
08050796	Tortora	C Bag kg.2.40	402 Kg
08050797	Grigio Fango	C Bag kg.2.40	402 Kg
08050798	Rosso Ossido	C Bag kg.2.40	402 Kg
08050799	Verde Salvia	C Bag kg.2.40	402 Kg
08050800	Verde Pino	C Bag kg.2.40	402 Kg
08050801	Turchese	C Bag kg.2.40	402 Kg
08050802	Artic Blue	C Bag kg.2.40	402 Kg
08050803	Quarzo Zaffiro	C Bag kg.2.40	402 Kg

DATA MEASURED at + 23°C and 50% humidity in the absence of ventilation. This may vary according to the specific site conditions such as temperature, ventilation, absorbency of the substrate and the covering materials. The images contained in this catalogue are for illustrative purposes only.

EPODET

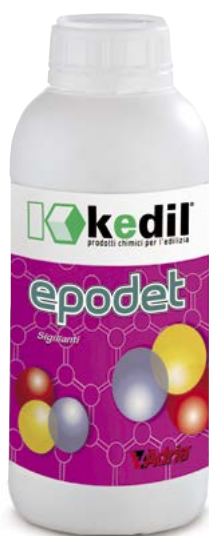

Aqueous based cleaner for removal from non-absorbent surfaces of residues of epoxy grouts. It enhances the colours and adds shine to epoxy grouts.

CHARACTERISTICS



100 - 200 g/m²



15 - 20 minutes



12 months in a dry place and in the original packaging supplied by us.

PRODUCT SPECIFICATIONS

CODE	08050805
COLOUR	Pale yellow
PACKAGE	Bottle 1 l.
PALLET	384 Kg

DATA MEASURED at +23°C and 50% humidity in the absence of ventilation. This may vary according to the specific site conditions such as temperature, ventilation, absorbency of the substrate and the covering materials. The images contained in this catalogue are for illustrative purposes only.

KEDIFIX



KEDIFIX is an MS polymer sealant adhesive, high modulus single component for construction. Thixotropic, reticulates through atmospheric humidity ensuring high performance of permanent elasticity, high resistance to aging and weathering. Free of solvents and isocyanates. **KEDIFIX** useful for gluing aluminium or plastic profiles on different supports, sealing joints and cracks in floors or walls. Paintable after hardening.

CHARACTERISTICS



15 - 20 minutes



12 months in a dry place and in the original packaging supplied by us.

COLOURS AVAILABLE:



Grigio chiaro



Jasmin



Cenere



Bianco



Manhattan



Transparent

PRODUCT SPECIFICATIONS

CODE	COLOUR	REFERENCE	PACK/WEIGHT	PALLET
08050952	Grigio chiaro	RAL 9002	Cartridge 290 ml	Boxes of 12 pieces
08050953	Jasmine	RAL 1013	Cartridge 290 ml	Boxes of 12 pieces
08050954	Cenere	RAL 7042	Cartridge 290 ml	Boxes of 12 pieces
08050955	Bianco		Bag 600 ml	Boxes of 12 pieces
08050956	Bianco		Cartridge 290 ml	Boxes of 12 pieces
08050957	Manhattan	RAL 7038	Cartridge 290 ml	Boxes of 12 pieces
08050958	Transparent		Cartridge 290 ml	Boxes of 12 pieces

DATA MEASURED at +23°C and 50% humidity in the absence of ventilation. This may vary according to the specific site conditions such as temperature, ventilation, absorbency of the substrate and the covering materials. The images contained in this catalogue are for illustrative purposes only.

KEDISIL N310



Low modulus professional neutral curing silicone. Formulated for the creation of expansion and perimeter joints, and applications on marble, granite, natural stone, ceramics, concrete, wood, metals, glass, refractory materials, hard plastics (PC, PMMA). Suitable for exterior and interior applications.

CAUTION: for porous stone and non-standard colours, contact the company's technical service centre before proceeding with the works.

CHARACTERISTICS



10 - 20 min.



12 months in a dry place and in the packaging provided by us, protected from frost and high temperatures

COLOURS AVAILABLE:



Beige



Manhattan



Cenere



Antracite



Jasmin



Transparent



Bianco



Tortora

COVERAGE TABLE

Joint size Metres/cartridge

5 x 5	mm	12
10 x 5	mm	6
10 x 10	mm	3
15 x 10	mm	2
20 x 10	mm	1.5
25 x 10	mm	1.25
30 x 10	mm	0.7
40 x 10	mm	0.4

PRODUCT SPECIFICATIONS

CODE	COLOUR	PACK/WEIGHT	PALLET
08050910	100 - Bianco	Cartridge 310 ml	Boxes of 24 pieces
08050935	202 - Manhattan	Cartridge 310 ml	Boxes of 24 pieces
08050920	203 - Cenere	Cartridge 310 ml	Boxes of 24 pieces
08050930	205 - Antracite	Cartridge 310 ml	Boxes of 24 pieces
08050905	000 - Trasparente	Cartridge 310 ml	Boxes of 24 pieces
08050915	101 - Jasmin	Cartridge 310 ml	Boxes of 24 pieces
08050925	300 - Beige	Cartridge 310 ml	Boxes of 24 pieces
08050927	303 - Tortora	Cartridge 310 ml	Boxes of 24 pieces
03095xxx	Other colours avail. with marketed brands	Cartridge 310 ml	Boxes of 24 pieces

DATA MEASURED at +23°C and 50% humidity in the absence of ventilation. This may vary according to the specific site conditions such as temperature, ventilation, absorbcency of the substrate and the covering materials. The images contained in this catalogue are for illustrative purposes only.



KEDILSANA_64
PRIMER SANA_64

DAMP-PROOF
COATINGS

KEDILSANA



NHL 5 repair mortar formulated with natural hydraulic lime, eco-friendly, fibre-reinforced, multipurpose with high resistance to sulphates and atmospheric decay specifically for renovations, new constructions and restorations of historical buildings or bio-building compliant works. Also ideal as a grouting mortar for reconstituted stone. Classification compliant plaster: R (mortar for repairs according to the standard EN 998-1)



DATA MEASURED at +23°C and 50% humidity in the absence of ventilation. This may vary according to the specific site conditions such as temperature, ventilation, absorptivity of the substrate and the covering materials. The images contained in this catalogue are for illustrative purposes only.

CHARACTERISTICS



6 hours



12 months in a dry place and in the packaging provided by us, protected from frost and high temperatures

PRODUCT SPECIFICATIONS

CODE	08090045
COLOUR	Straw
PACKAGE	25 Kg bag
PALLET	1.500 Kg

PRIMER SANA



PRIMER SANA is a mixture of pre-dispersed silica and silicone derivatives suitably modified and stabilised to provide protection against efflorescence and a barrier to capillary rising damp. Particularly suitable for the preparation of surfaces to be plastered with dehumidifying plaster. Also suitable as salt protection for exposed brick walls. Prevents the penetration of dirt conveyed by water, making surfaces self-cleaning. **Also suitable as a damp-proof coating for natural stone. Excellent as an oil and water repellent.**

CHARACTERISTICS



100 - 150 g/m²



6 hours



12 months in a dry place and in the original packaging supplied by us.

PRODUCT SPECIFICATIONS

CODE	08090047	08090050
COLOUR	Transparent	Transparent
PACKAGE	Jerrycan 5 Kg	Jerrycan 25 Kg
PALLET	480 Kg	600 Kg

DATA MEASURED at +23°C and 50% humidity in the absence of ventilation. This may vary according to the specific site conditions such as temperature, ventilation, absorptivity of the substrate and the covering materials. The images contained in this catalogue are for illustrative purposes only.





MACRON_68
MACRON R_68
MACRON F_69
MACRON F RAPID_69
MACRON ABF_70
MACRON FLUID_70
MACRON FER_71
KELASTO_71

REPAIRING
CONCRETE

MACRON



Normal setting mortar for concrete repair. Thixotropic and fibre-reinforced, non-shrink pre-mixed compound, consisting of cement binders, chemical additives and aggregates. The selected particle size gives it high mechanical strength combined with the possibility to develop self-supporting high-thickness coatings without the need for additional formwork on the deteriorated structure.

The product is class R3 as described in EN 1504-3.

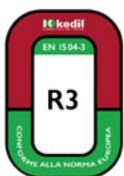

DATA MEASURED at +23°C and 50% humidity in the absence of ventilation. This may vary according to the specific site conditions such as temperature, ventilation, absorptivity of the substrate and the covering materials. The images contained in this catalogue are for illustrative purposes only.

CHARACTERISTICS



Powder: 18 kg/m² x cm of thickness



60 minutes



12 months in a dry place and in the original packaging supplied by us.

PRODUCT SPECIFICATIONS

CODE	08090020
COLOUR	Grey
PACKAGE	25 Kg bag
PALLET	1.400 Kg

MACRON R



Rapid setting mortar for concrete repair. Thixotropic and fibre-reinforced, non-shrink pre-mixed compound, consisting of cement binders, chemical additives and aggregates. The selected particle size gives it high mechanical strength combined with the possibility of adding thick self-supporting levels without the need for formworking of the deteriorated structure.

The product is class R4 as described in EN 1504-3.

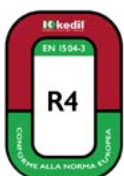

DATA MEASURED at + 23°C and 50% humidity in the absence of ventilation. This may vary according to the specific site conditions such as temperature, ventilation, absorptivity of the substrate and the covering materials. The images contained in this catalogue are for illustrative purposes only.

CHARACTERISTICS



Powder: 19 kg/m² x cm of thickness



20 minutes



12 months in a dry place and in the original packaging supplied by us.

PRODUCT SPECIFICATIONS

CODE	08090010
COLOUR	Grey
PACKAGE	25 Kg bag
PALLET	1.400 Kg

MACRON F



Fibre-reinforced, non-shrink concrete repair skim coat mortar consisting of cementitious binders, chemical additives and aggregates. The selected particle size with maximum tip 0.5 millimetres, gives added mechanical strength with a natural finish.

MACRON F allows a thickness of 4 centimetres in a single coat.

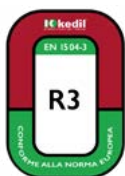

DATA MEASURED at +23°C and 50% humidity in the absence of ventilation. This may vary according to the specific site conditions such as temperature, ventilation, absorbency of the substrate and the covering materials. The images contained in this catalogue are for illustrative purposes only.

MACRON F RAPIDO



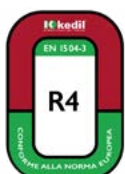

Rapid setting mortar for concrete repair. Fibre-reinforced, non-shrink, consisting of cement binders, chemical additives and aggregates. The selected particle size with maximum tip 0.5 millimetres, gives added mechanical strength with a natural finish. **MACRON F RAPIDO** allows a thickness of 4 centimetres in a single coat.

The product is class R4 as described in EN 1504-3.



DATA MEASURED at +23°C and 50% humidity in the absence of ventilation. This may vary according to the specific site conditions such as temperature, ventilation, absorbency of the substrate and the covering materials. The images contained in this catalogue are for illustrative purposes only.



CHARACTERISTICS

-  Powder: 19 kg/m² x cm of thickness
-  60 minutes
-  12 months in a dry place and in the original packaging supplied by us.

PRODUCT SPECIFICATIONS

CODE	08090015
COLOUR	Grey
PACKAGE	25 Kg bag
PALLET	1.500 Kg

CHARACTERISTICS

-  Powder: 18 kg/m² x cm of thickness
-  20 minutes
-  12 months in a dry place and in the original packaging supplied by us.

PRODUCT SPECIFICATIONS

CODE	08090037
COLOUR	Grey
PACKAGE	25 Kg bag
PALLET	1500 Kg

MACRON ABF



Glass fibre reinforced, premixed compensated shrinkage mortar with ultra-quick setting and hardening for applications up to -5°C . Ideal for concrete repair, for industrial, road, airport floorings, for the restoration of motorway joints, hydraulic structures and floors.

DATA MEASURED at $+23^{\circ}\text{C}$ and 50% humidity in the absence of ventilation. This may vary according to the specific site conditions such as temperature, ventilation, absorbency of the substrate and the covering materials. The images contained in this catalogue are for illustrative purposes only.

CHARACTERISTICS



Powder: $19\text{ kg/m}^2 \times \text{cm}$ of thickness



15 minutes



12 months in a dry place and in the original packaging supplied by us.

PRODUCT SPECIFICATIONS

CODE	08090025
COLOUR	Nero
PACKAGE	Bag 25 kg
PALLET	1500 kg

MACRON FLUID



Premixed compensated shrinkage mortar based on hydraulic binders. The product is ready for use; mixed only with water, it produces a liquid mortar, without segregation with excellent flow characteristics. After setting, **MACRON FLUID** achieves high mechanical resistance, excellent adhesion to both to steel and to concrete making it suitable and specific for vibrating machinery precision anchoring that is subject to high temperature fluctuations in addition to the fixing of pre-cast concrete and metallic elements.

DATA MEASURED at $+23^{\circ}\text{C}$ and 50% humidity in the absence of ventilation. This may vary according to the specific site conditions such as temperature, ventilation, absorbency of the substrate and the covering materials. The images contained in this catalogue are for illustrative purposes only.

CHARACTERISTICS



Powder: $19\text{ kg/m}^2 \times \text{cm}$ of thickness



60 minutes



12 months in a dry place and in the original packaging supplied by us.

PRODUCT SPECIFICATIONS

CODE	08090040
COLOUR	Grey
PACKAGE	25 Kg bag
PALLET	1.000 Kg



MACRON FER



Pre-mixed, composed of cement binders, selected silica aggregates, anti-carbonate chemical additives and synthetic resins. Used on degraded concrete substrates with reinforcing rods exposed and oxidised, it creates on irons a protective alkaline-passivating layer and an anti-carbonate bonding base on concrete to be repaired.

DATA MEASURED at +23°C and 50% humidity in the absence of ventilation. This may vary according to the specific site conditions such as temperature, ventilation, absorptency of the substrate and the covering materials. The images contained in this catalogue are for illustrative purposes only.

CHARACTERISTICS

-  Powder: 1.7 kg/m² x mm of thickness
-  60 minutes
-  12 months in a dry place and in the original packaging supplied by us.

PRODUCT SPECIFICATIONS

CODE	08090030
COLOUR	Reddish
PACKAGE	Bucket 5 Kg
PALLET	400 Kg

KELASTO



Elastomeric anti-cracking, anti-carbonation paint for the protection of concrete structures

DATA MEASURED at +23°C and 50% humidity in the absence of ventilation. This may vary according to the specific site conditions such as temperature, ventilation, absorptency of the substrate and the covering materials. The images contained in this catalogue are for illustrative purposes only.

CHARACTERISTICS

-  Liquid: 250 g x m²
-  60 minutes
-  12 months in a dry place and in the original packaging supplied by us.

PRODUCT SPECIFICATIONS

CODE	08090085	08090080
COLOUR	White	Manhattan
PACKAGE	Bucket 10 Kg	Bucket 10 Kg
PALLET	600 Kg	600 Kg





SK 300 LEGNO_74
FIRST SK_74
GM ONE_75
WOOD ONE_75

LAYING OF WOOD

SK 300 WOOD



Two-component polymer sealing adhesive high performance elastic beige or walnut coloured. Suitable for the laying of wooden floors and parquet, after inspection of the residual moisture of the substrate that must always be less than 2%. The product can be applied on cementitious levelling, anhydrite screeds after the use of specific primers, concrete, existing ceramic floors, heated floors and stone materials. If the humidity is higher than 2%, and up to 6%, laying is also possible using **PRIMER SK**. Classified as an R2 adhesive (according to EN 12004)

DATA MEASURED at +23°C and 50% humidity in the absence of ventilation. This may vary according to the specific site conditions such as temperature, ventilation, absorbcency of the substrate and the covering materials. The images contained in this catalogue are for illustrative purposes only.

CHARACTERISTICS



0.9 - 1.2 kg/m²



Open time 120 minutes



12 months in a dry place and in the original packaging supplied by us.

PRODUCT SPECIFICATIONS

CODE	08060027
COLOUR	Beige
PACKAGE	Bucket 12.5 Kg
WEIGHT	600Kg

PRIMER SK



Moisture barrier for screeds and levelling based on cement, gypsum or anhydrite with residual humidity less than 4%, before laying the wood or moisture-sensitive materials. Also suitable for use as a hardener.

DATA MEASURED at +23°C and 50% humidity in the absence of ventilation. This may vary according to the specific site conditions such as temperature, ventilation, absorbcency of the substrate and the covering materials. The images contained in this catalogue are for illustrative purposes only.

CHARACTERISTICS



200 - 300 gr/m² depending on the condition of the substrate



12 months in a dry place and in the original packaging supplied by us.
Protect against frost

PRODUCT SPECIFICATIONS

CODE	08060050
COLOUR	Transparent in colour
PACKAGE	Bucket 10 Kg
WEIGHT	760 Kg

GM ONE



Single-component silane adhesive for LVT, SPC, PVC, rubber and linoleum. Suitable for laying on all types of substrates, including heating ones. It is particularly resistant to moisture, water, heat and static and dynamic loads. Perfect for commercial and industrial interiors, it is safe for the user because it is free of isocyanate and solvent.

CHARACTERISTICS

-  1.2 kg/m²
-  12 - 24 h on floors.
-  Open time 30 minutes
-  12 months in a dry place and in the original packaging supplied by us.

PRODUCT SPECIFICATIONS



CODE	08060040
COLOUR	Beige
PACKAGE	Bucket 15 Kg
WEIGHT	660 Kg

WOOD ONE



One-component silane moisture-curing adhesive, ready for use, odourless, completely free of water, for fixing with high elastic modulus and high resistance. Ideal for pre-finished and traditional wooden floors. The absence of solvents and the very low concentration of volatile organic compounds provide a higher level of safety for the user and for the environment.

CHARACTERISTICS

-  0.9 - 1.2 kg/m²
-  Open time 120 minutes
-  12 months in a dry place and in the original packaging supplied by us.

PRODUCT SPECIFICATIONS

CODE	08060015
COLOUR	Beige
PACKAGE	Bucket 15 Kg
WEIGHT	600 Kg

DATA MEASURED at +23°C and 50% humidity in the absence of ventilation. This may vary according to the specific site conditions such as temperature, ventilation, absorbency of the substrate and the covering materials. The images contained in this catalogue are for illustrative purposes only.



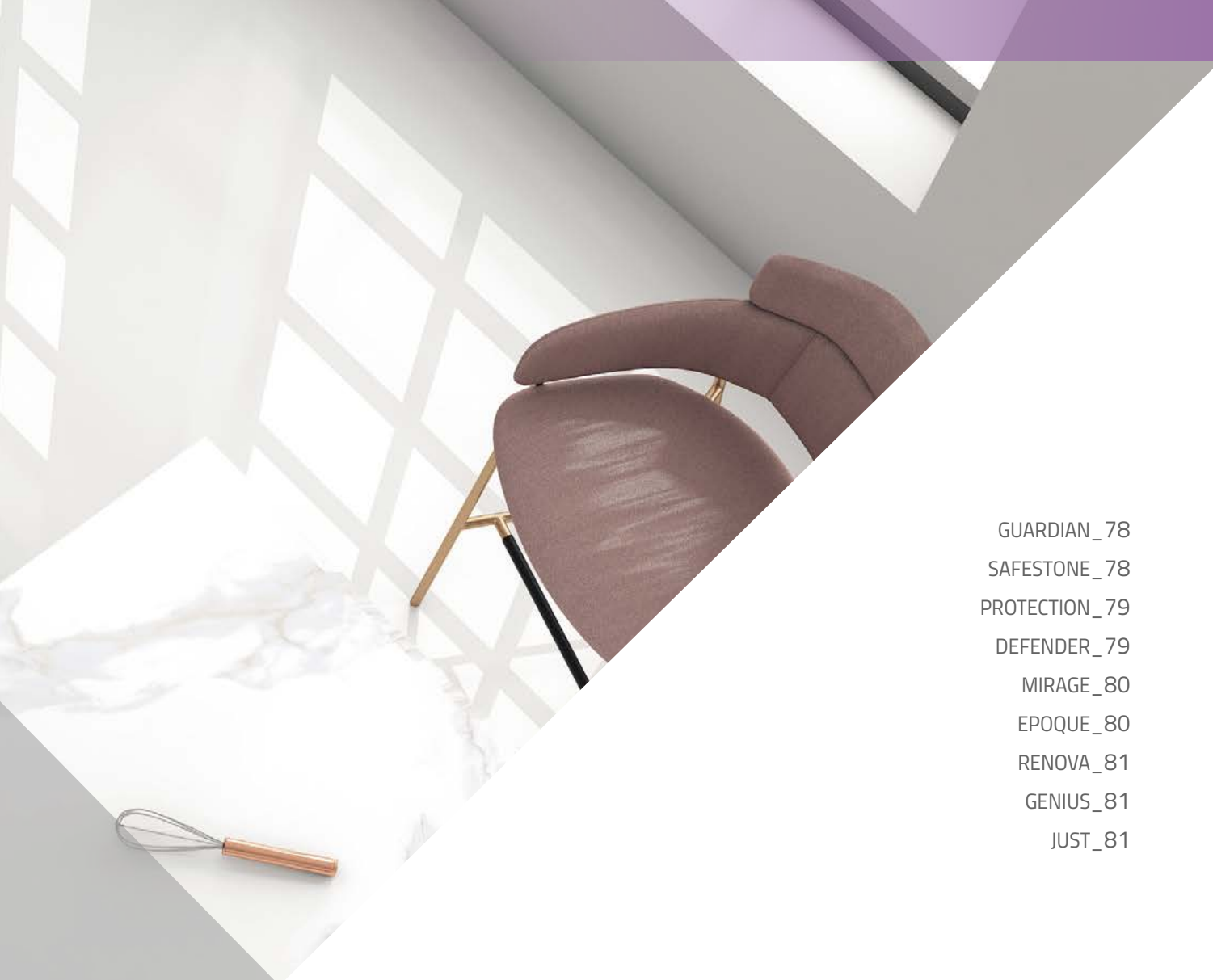

GUARDIAN_78
SAFESTONE_78
PROTECTION_79
DEFENDER_79
MIRAGE_80
EPOQUE_80
RENOVA_81
GENIUS_81
JUST_81

PROTECTION AND MAINTENANCE OF SURFACES

GUARDIAN



Impregnating stain protection water-oil repellent agent with **natural effect** for marble, granite, cementitious substrate, cotto, exposed bricks. **Water-based** low odour formulation for **interior and exterior** applications. It does not contain synthetic solvents or other substances that are harmful to the environment and is not labelled as hazardous.

DATA MEASURED at +23°C and 50% humidity in the absence of ventilation. This may vary according to the specific site conditions such as temperature, ventilation, absorbency of the substrate and the covering materials. The images contained in this catalogue are for illustrative purposes only.

CHARACTERISTICS



15 -25 m²/l



12 months unopened in its original packaging. 3 months after opening. Protect from frost and high temperatures.

PRODUCT SPECIFICATIONS

CODE	02520005	02520010	02520015
COLOUR	Opalescent white	Opalescent white	Opalescent white
PACKAGE	Bottle 1 Kg	Tin 5 litres	Tin 20 litre

SAFESTONE

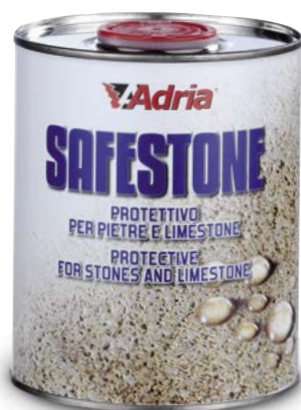

Impregnating stain protection water-oil repellent agent with **natural effect** ideal for very absorbent materials such as limestone, natural stone, terracotta, exposed bricks, agglomerates and cementitious elements. Solvent-based formulation, suitable for **interior and exterior** applications.

DATA MEASURED at +23°C and 50% humidity in the absence of ventilation. This may vary according to the specific site conditions such as temperature, ventilation, absorbency of the substrate and the covering materials. The images contained in this catalogue are for illustrative purposes only.

CHARACTERISTICS



10 -20 m²/l



24 months unopened in its original packaging. 3 months after opening. Protect from frost and high temperatures.

PRODUCT SPECIFICATIONS

CODE	02515060	02515065	02515070
COLOUR	Transparent in colour	Transparent in colour	Transparent in colour
PACKAGE	Bottle 1 Kg	Tin 5 litres	Tin 20 litre

PROTECTION

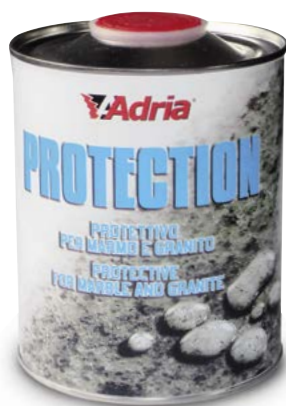

Impregnating stain protection water-oil repellent agent with **natural effect, for granite**, unglazed tiles. Ideal to achieve high protection, even after a few hours. Solvent-based formulation, preferably indicated for **interior** use.

CHARACTERISTICS



15 -25 m²/l



24 months unopened in its original packaging. 6 months after opening in a cool dry place.

PRODUCT SPECIFICATIONS

CODE	02515005	02515010	02515020
COLOUR	Transparent in colour	Transparent in colour	Transparent in colour
PACKAGE	Bottle 1 Kg	Tin 5 litres	Tin 20 litre

DATA MEASURED at +23°C and 50% humidity in the absence of ventilation. This may vary according to the specific site conditions such as temperature, ventilation, absorbcency of the substrate and the covering materials. The images contained in this catalogue are for illustrative purposes only.

DEFENDER

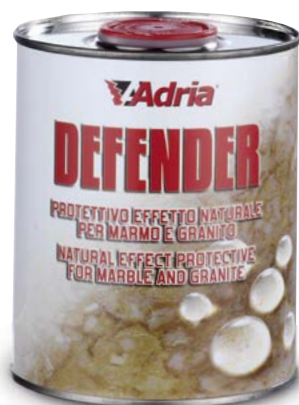

Impregnating stain protection water-oil repellent agent with **natural effect, for marble and granite**. Particularly suited for gres porcellanato. Solvent-based formulation, suitable for **interior and exterior** applications. Suitable for use when you need a high level of protection without altering the natural colour of the stone.

CHARACTERISTICS



15 -30 m²/l



24 months unopened in its original packaging. 6 months after opening in a cool dry place.

PRODUCT SPECIFICATIONS

CODE	02515030	02515035	02515040
COLOUR	Transparent in colour	Transparent in colour	Transparent in colour
PACKAGE	Bottle 1 Kg	Tin 5 litres	Tin 20 litre

DATA MEASURED at +23°C and 50% humidity in the absence of ventilation. This may vary according to the specific site conditions such as temperature, ventilation, absorbcency of the substrate and the covering materials. The images contained in this catalogue are for illustrative purposes only.

MIRAGE



Reviving (wet effect) impregnating water-oil repellent agent, for marble, granite and natural stone. Ideal for **rough, bush-hammered**, coarse polished, saw cut surfaces. This product needs be applied in several coats, depending on the absorption of the treated materials. Solvent-based formulation, suitable for **exterior** and interior applications.

CHARACTERISTICS



5 - 15 m²/l



24 months unopened in its original packaging. 6 months after opening in a cool dry place.

PRODUCT SPECIFICATIONS

CODE	02515160	02515165	02515170
COLOUR	Transparent yellow	Transparent yellow	Transparent yellow
PACKAGE	Bottle 1 Kg	Tin 5 litres	Tin 20 litre

DATA MEASURED at +23°C and 50% humidity in the absence of ventilation. This may vary according to the specific site conditions such as temperature, ventilation, absorbency of the substrate and the covering materials. The images contained in this catalogue are for illustrative purposes only.

EPOQUE

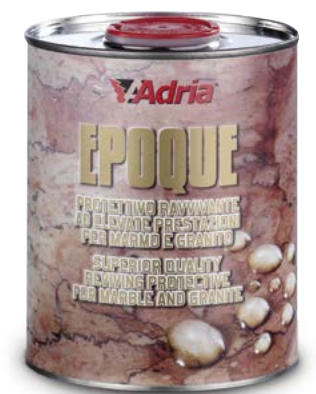

Reviving (wet effect) impregnating water-oil repellent agent, for marble, granite and absorbent agglomerates. Ideal for smooth, brushed and polished surfaces. Solvent-based formulation specific for **exterior** applications, given the high resistance to light and weathering. This product needs be applied in several coats, depending on the absorption of the treated materials.

CHARACTERISTICS



8 - 20 m²/l



24 months unopened in its original packaging. 6 months after opening in a cool dry place.

PRODUCT SPECIFICATIONS

CODE	02515120	02515125	02515130
COLOUR	Transparent yellow	Transparent yellow	Transparent yellow
PACKAGE	Bottle 1 Kg	Tin 5 litres	Tin 20 litre

DATA MEASURED at +23°C and 50% humidity in the absence of ventilation. This may vary according to the specific site conditions such as temperature, ventilation, absorbency of the substrate and the covering materials. The images contained in this catalogue are for illustrative purposes only.

RENOVA



Reviving (wet effect) impregnating water-oil repellent agent, for marble, granite and natural stone, ideal for sandblasted, brushed and antiqued surfaces. Solvent-based formulation, preferably indicated for **interior** use.

CHARACTERISTICS



8 -20 m²/l



24 months unopened in its original packaging. 6 months after opening in a cool dry place.

PRODUCT SPECIFICATIONS

CODE	02515100	02515105	02515110
COLOUR	Transparent yellow	Transparent yellow	Transparent yellow
PACKAGE	Bottle 1 Kg	Tin 5 litres	Tin 20 litre

DATA MEASURED at +23°C and 50% humidity in the absence of ventilation. This may vary according to the specific site conditions such as temperature, ventilation, absorbercy of the substrate and the covering materials. The images contained in this catalogue are for illustrative purposes only.

GENIUS



Reviving (wet effect) for reconstituted quartz materials or, in general, for low absorption agglomerates. Easy to apply without leaving lines. Solvent-based formulation for **interior** applications. Ideal for **kitchen tops** because certified for food contact.

CHARACTERISTICS



15 -30 m²/l



24 months unopened in its original packaging. 6 months after opening in a cool dry place.

PRODUCT SPECIFICATIONS

CODE	02515140	02515145	02515150
COLOUR	Transparent in colour	Transparent in colour	Transparent in colour
PACKAGE	Bottle 1 Kg	Tin 5 litres	Tin 20 litre

DATA MEASURED at +23°C and 50% humidity in the absence of ventilation. This may vary according to the specific site conditions such as temperature, ventilation, absorbercy of the substrate and the covering materials. The images contained in this catalogue are for illustrative purposes only.

JUST



Impregnating stain protection water-oil repellent agent for **terraces, balconies** or, in general, coatings in natural stone, cotto, clinker, cement and on severely damaged absorbent surfaces. Protects against water infiltration, mould and efflorescence, even in the event of prolonged water stagnation. Solvent-based formulation, suitable for exterior and interior applications.

CHARACTERISTICS



10 -20 m²/l



24 months unopened in its original packaging. 6 months after opening in a cool dry place.

PRODUCT SPECIFICATIONS

CODE	02515041	02515042	02515144
COLOUR	Transparent in colour	Transparent in colour	Transparent in colour
PACKAGE	Tin 1 litre	Tin 5 litres	Tin 20 litres

DATA MEASURED at +23°C and 50% humidity in the absence of ventilation. This may vary according to the specific site conditions such as temperature, ventilation, absorbercy of the substrate and the covering materials. The images contained in this catalogue are for illustrative purposes only.





ACCESSORIES

- GRES PRO ORO_84
- GRES PRO BIANCO_84
- TOP GRES AZZURRO_84
- PRO STONE_85
- PRO BAR_85
- PRO TRAS_85
- EVOXY_86
- GUN FOR EVOXY AND NOZZLE_86
- SEAM ROLLER_87
- MDM GRINDER_87
- DIAMOND SLITTING WHEELS FOR CHAMFERING AND GRINDING_87
- PUTTY KNIFE_88
- SPONGES AND FELTS_88
- WASH TRAYS_88
- SPACERS_89
- LEVELLING SPACERS FOR MARBLE, GRANITE, AGGLOMERATES_89
- LEVELLING WEDGES_89
- LEVELLING SPACERS_90
- POLYETHYLENE FOAM FILLER_90
- TILE AND FLOATING FLOORS KIT_91
- WATER DRAIN GRATE WITH PIPE_91

GRES PRO ORO



Welded continuous rim cutting disc for use with angle grinders. Suitable for straight cuts. For fast precision cutting.

CHARACTERISTICS

Porcelain stoneware, vitreous/vitrified materials, ceramics, granite, marble

Dry

PRODUCT SPECIFICATIONS

CODE	03525008
CIRCUMFERENCE	115
SECTORS	CC 1,6x5,5 gold
CONNECTION	Hole 22,2 mm
REVS	12.000

GRES PRO BIANCO



Welded continuous rim cutting disc for use with angle grinders. Suitable for making various types of cut in thin materials. For fast precision cutting.

CHARACTERISTICS

Porcelain stoneware, vitreous/vitrified materials, ceramics, granite, marble

Dry

PRODUCT SPECIFICATIONS

CODE	03525005
CIRCUMFERENCE	115
SECTORS	CC 1.2x10 white
CONNECTION	Hole 22,2 mm
REVS	12.000

TOP GRES AZZURRO

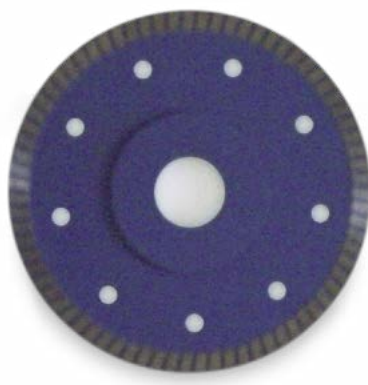

Welded rim turbo cutting disc with central reinforcement for use with angle grinders. Suitable for making various types of cut in thin materials. For fast precision cutting.

CHARACTERISTICS

Porcelain stoneware, vitreous/vitrified materials, ceramics, granite, marble

Dry

PRODUCT SPECIFICATIONS

CODE	03525010
CIRCUMFERENCE	115
SECTORS	CC 1,6x5,5 gold
CONNECTION	Hole 22,2 mm
REVS	12.000

PRO STONE



- Post-laying protective sheeting is ideal for protecting natural stone as it is breathable and also highly resistant to the accidental dropping of heavy tools
- Reduced costs due to reuse
- Puncture-proof and high mechanical strength
- Heat-set, resulting in high abrasion resistance, less lint and fibre fly, and reusable

PRODUCT SPECIFICATIONS

CODE	08030143
COLOUR	White
PACKAGE	50m ²
PALLET	12 rolls

PRO BAR



- Our PROBAR protective membrane is laid with the film face-down and secured with adhesive tape. It can therefore be laid rapidly in small and large spaces, ideal for mechanical protection against falling tools and flooring is protected from the spillage of paints and solvents.

PRODUCT SPECIFICATIONS

CODE	08030145
COLOUR	Grey
PACKAGE	50m ²
PALLET	12 rolls

PRO TRAS



- Inexpensive coverage against dry dirt from falling plaster and mortar
- Simple scaffolding pad
- Heat-set, resulting in high abrasion resistance, less lint and fibre fly, and reusable
- Breathable post-laying protective sheeting

PRODUCT SPECIFICATIONS

CODE	08030147
COLOUR	Grey
PACKAGE	50m ²
PALLET	12 rolls

EVOXY

Two-component quick-setting mastic available in different colours. Ideal for fixing ceramics, agglomerates and natural stones.



CHARACTERISTICS



10 - 20 min.



12 months in a dry place and in the packaging provided by us, protected from frost and high temperatures

COLOURS AVAILABLE:



Bianco



Beige



Grey

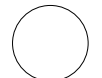

Transparent



Marrone



Nero



Tortora

PRODUCT SPECIFICATIONS

CODE	COLOUR	PACK/WEIGHT	PALLET
03020120	100 - Bianco	Cartridge 250 ml	Boxes of 14 pieces
03020121	300 - Beige	Cartridge 250 ml	Boxes of 14 pieces
03020122	000 - Grigio	Cartridge 250 ml	Boxes of 14 pieces
03020124	000 - Marrone	Cartridge 250 ml	Boxes of 14 pieces
03020125	000 - Nero	Cartridge 250 ml	Boxes of 14 pieces
03020133	303 - Tortora	Cartridge 250 ml	Boxes of 14 pieces
03020135	000 - Trasparente	Cartridge 250 ml	Boxes of 14 pieces
03020107	100 - Bianco	Tin 1 litre	Boxes of 12 pieces
03020093	000 - Nero	Tin 1 litre	Boxes of 12 pieces
03020109	000 - Grigio	Tin 1 litre	Boxes of 12 pieces
03020095	300 - Beige	Tin 1 litre	Boxes of 12 pieces
03020075	000 - Trasparente	Tin 1 litre	Boxes of 12 pieces

GUN FOR EVOXY AND NOZZLES

Gun suitable for extrusion of **EVOXY** cartridge and nozzles.



PRODUCT SPECIFICATIONS

CODE	03045121	03045124
PACKAGE	1 Piece	Nozzle

SPIKED ROLLER



Spiked roller size 20 x 8 cm, ideal for removing air occluded in the self-levelling compound.

PRODUCT SPECIFICATIONS

CODE 08070010

PACKAGE 1 Piece

MDM GRINDER



Multi-hole metal diamond cup wheel for grinding concrete surfaces and roughing existing ceramic or natural stone floors before overlaying.

- MA14 thread and 22.2 mm hole
- Good disposal of dust generated by roughing
- Allows proper air circulation
- Avoids tool overheating especially when used dry
- Grit size 0.

PRODUCT SPECIFICATIONS

CODE 03535212-03535213
03535225-03535250
03535260

DIAMETER Ø115
Ø125
Ø180

PACKAGE 1 Piece
1 Piece
1 Piece

DIAMOND GRINDING WHEELS FOR CHAMFERING AND GRINDING

Lamellar diamond grinding wheel Ø 115 mm for chamfering and grinding ceramics, quartz, granite and marble.



PRODUCT SPECIFICATIONS

CODE	PACKAGE	GRAIN	COLOUR
00170786	1 Piece	60	Verde
00170787	1 Piece	120	Nero
00170788	1 Piece	200	Rosso

PUTTY KNIVES



RUBBER TROWEL

GROUT FLOAT

PRODUCT SPECIFICATIONS

CODE	ARTICLE	PACKAGE
08070201	Blue rubber trowel	1 Piece
08070210	Grout float	1 Piece
08070202	Blue rubber spare	1 Piece

SPONGES AND FELTS



SPONGE

FELT

PRODUCT SPECIFICATIONS

CODE	ARTICLE	PACKAGE
08070230	Yellow sponge float	1 Piece
08070240	Trowel with 2 felts	1 Piece

WASH TRAYS

SPARE PART
FELTSPARE PART
SPONGETRAY
3 ROLLERS

PRODUCT SPECIFICATIONS

CODE	ARTICLE	PACKAGE
08070220	3 rollers tray	1 Piece
08070235	Replacement sponge	1 Piece
08070245	Black felt replacement	1 Piece
08070243	White felt replacement	1 Piece
08070250	Yellow sponge 17x11x17	1 Piece
08070225	Cellulose sponge float	1 Piece
08070227	Cellulose sponge spares	1 Piece

SPACERS



PRODUCT SPECIFICATIONS

DIMENS.	CODE	CODE T	CODE Y	PACKAGE
1 mm	08070300	08070350		1000 pc.
2 mm	08070305	08070355		1000 pc.
3 mm	08070310	08070360		1000 pc.
3 mm			08070400	1000 pc.
4 mm	08070315	08070365		1000 pc.
5 mm	08070320	08070370		1000 pc.
7 mm	08070325	08070375		1000 pc.
10 mm	08070330	08070380		500 pc.
Wedges	08070450			1000 pc.

LEVELING SPACERS FOR MARBLE, GRANITE, AGGLOMERATES



System with shock-absorbing pad to prevent scratches on delicate materials during tightening.

PRODUCT SPECIFICATIONS

CODE	ARTICLE	PACKAGE
08070417	Grey Twister	100 pc.
08070406	Washer f/twister	300 pc.
08070434	Level stone 1 mm	200 pc.

LEVELLING WEDGES

Wedge spacers suitable for a new laying system with thickness from 0.5 to 3 mm.



PRODUCT SPECIFICATIONS

CODE	ARTICLE	PACKAGE
08070442	Levelling spacers with clear clip 0.5 mm	100 pc.
08070435	Levelling spacers with clear clip 2 mm	100 pc.
08070436	Levelling spacers with clear clip 1 mm	100 pc.
08070437	Levelling spacers with clear clip 3 mm	100 pc.
08070438	Levelling spacers with clear clip 1.5 mm	100 pc.
08070439	Levelling spac. clear clip 2 mm	100 pc.
08070440	Plastic clamp for levelling wedges	1 pz.
08070441	Levelling wedges	50 pc.

LEVELING SPACERS



FOR THICKNESS FROM 3 to 12 mm

The innovative laying system and adjustment of all types of ceramics and tiles. Particularly effective on large tiles. Unique in offering smooth (basic), cross and T spacers.

PRODUCT SPECIFICATIONS

CODE	ARTICLE	PACKAGE
08070414	Cross level 2 m	Bag of 250 pc.
08070416	Cross level 3 m	Bag of 250 pc.
08070418	Cross level 4 m	Bag of 250 pc.
08070422	T level 2 m	Bag of 250 pc.
08070424	T level 3 m	Bag of 250 pc.
08070426	T level 4 m	Bag of 250 pc.
08070430	Basic Level 1.7mm	Bag of 250 pc.
08070432	Basic Level 1mm	Bag of 250 pc.
08070415	Black Twister	Bag of 100 pc.
08070429	Level base 2 mm	Bag of 250 pc.

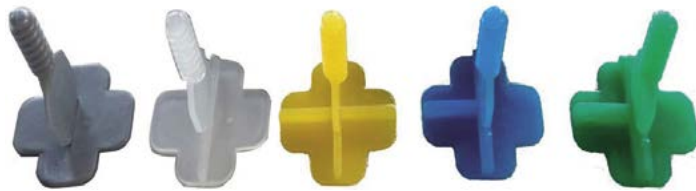

QUANTITY OF LEVEL TWISTERS PER SQUARE METER

SQUARE LAYING

TILES cmxcm	30x30	40x40	45x45	50x50	60x60	80x80	90x90	120x120
U/SQM	11	6	5	4	9	7	4	4

RECTANGULAR LAYING

TILES cmxcm	40x80	45x90	120x30	120x40	120x60
U/SQM	11	6	5	4	9

STAGGERED LAYING

TILES cmxcm	10x100	12x100	15x100	20x100	10x120	12x120	15x120	20x120
U/SQM	40	33	27	20	40	34	27	20

TILES cmxcm	10x80	12x80	15x80	20x80	22x90	45x90	120x60	40x80
U/SQM	37	30	25	18	15	8	7	9

POLYETHYLENE FOAM FILLER



Filtene is a joint-filler made of closed-cell expanded polyethylene, which is compactable, resilient, chemically inert, and doesn't stick to other sealants.

PRODUCT SPECIFICATIONS

CODE	DIMENSION	PACKAGE
08070525	6 mm	on request

TILE AND FLOATING FLOORS KIT



Floor supports for laying floating floors from 7 to 225 mm high.

PRODUCT SPECIFICATIONS

CODE	ARTICLE	PACKAGE
08070501	FIXED SUPPORT 7mm for floating floors	Bag of 50 pc.
08070502	FIXED SUPPORT 14mm for floating floors	Bag of 50 pc.
08070503	3 pcs. SUPPORT KIT for floating floors 28-36mm	Bag of 20 pc.
08070504	3 pcs. SUPPORT KIT for floating floors 36-51mm	Bag of 20 pc.
08070506	3 pcs. SUPPORT KIT for floating floors 52-82mm	Bag of 20 pc.
08070507	3 pcs. SUPPORT KIT for floating floors 82-135mm	Bag of 20 pc.
08070508	3 pcs. SUPPORT KIT for floating floors 133-225mm	Bag of 20 pc.

WATER DRAIN GRATE WITH PIPE

Grate for water drainage equipped with a 50 cm, Ø110 cm pipe, for quick laying.

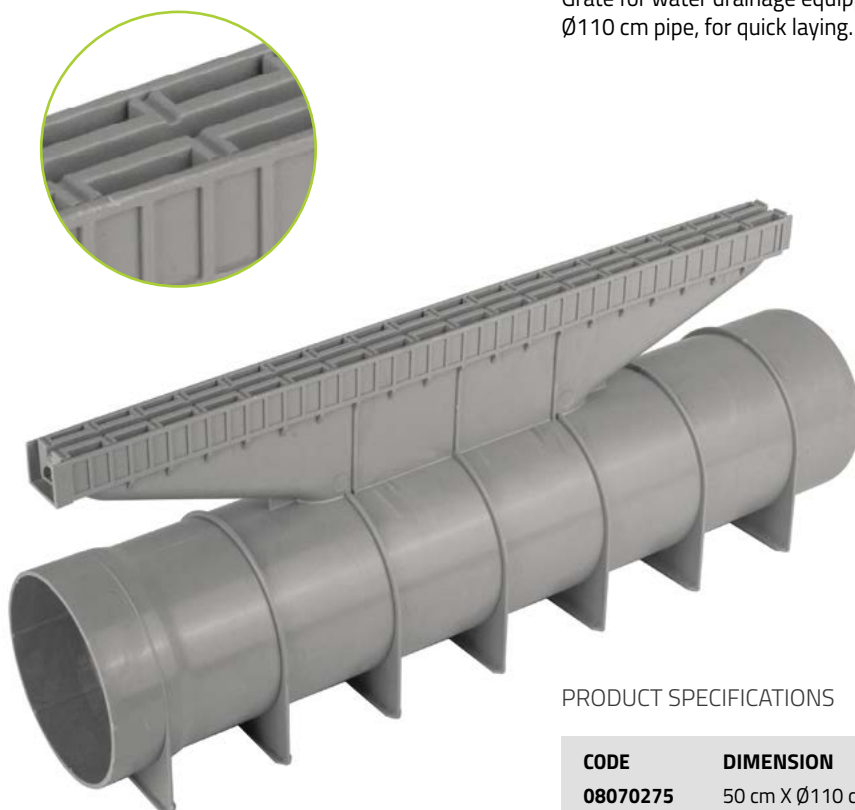

PRODUCT SPECIFICATIONS

CODE	DIMENSION	PACKAGE
08070275	50 cm X Ø110 cm	on request

ADHESIVES

Adhesives requirements (Class according to UNI EN 12004)												
Target environment:	Screed references (Strength class according to UNI EN 13813 or equal performance)	Tiles - Water absorption (according to UNI EN 14411) and Length of the longer side (cm)										
RESIDENTIAL FLOORING		AA ≤ 3%					AA > 3%					
		≤ 30	≤ 60	≤ 90	≤ 120	> 120	≤ 30	≤ 60	≤ 90	≤ 120	> 120	
Substrate type (See table 3)	Cementitious screed with heating	C20 F3	C2			C2S1/S2		C2	C2		C2S1/S2	
	Cementitious screed without heating	C16 F3	C1	C2	C2	C2		C1		C2	C2	
	Sulphate-based screed (anhydrite) (anhydrite) with heating	C20 F3	C2	C2		C2S1/S2		C2	C2		C2S1/S2	
	Sulphate-based screed (anhydrite) (anhydrite) without heating	C16 F3	C1	C2	C2	C2		C1		C2	C2	
	Cast-in-place concrete		C2		C2	C2		C2		C2	C2	
	Pre-cast concrete		C2	C2-C2S1/S2				C2	C2	C2-C2S1/S2		
	Liquid-applied waterproofing products CEMENT (CM)		C2	C2		C2		C1	C2		C2	
	Pre-existing substrates with organic adhesive residues (with cementitious adhesives ⁽¹⁾)		C2		C2	C2-C2S1/S2		C2		C2	C2S1/S2	
	Pre-existing tiles/mosaic/stones		C2		C2	C2		C2		C2	C2	
	Pre-existing metal surfaces		R1-R2					R1-R2				

LEGEND	adhesive signs	provide adhesives or systems that guarantee full bed (e.g. double-spreading)
		size the joints according to the elastic modulus of the sealant and the lattice of the expansion joints
		laying excluded unless otherwise prescribed

ADHESIVES

Adhesives requirements						
Target environment:	Screed references	Tiles - Water absorption (according to UNI EN 14411) and Length of the longer side (cm)				
FLOORING PUBLIC/COMMERCIAL INTERIOR		AA \leq 3% and AA>3%				
		\leq 30	\leq 60	\leq 90	\leq 120	>120
Cementitious screed with heating	C25 F4	C2	C2		C2S1/S2	
Cementitious screed without heating	C20 F3	C1	C2		C2	
Sulphate-based screed (anhydrite) with heating	C25 F4	C2	C2		C2S1/S2	
Sulphate-based screed (anhydrite) without heating	C20 F3	C1	C2		C2	
Cast-in-place concrete		C2	C2		C2	
Pre-cast concrete		C2	C2-C2S1/S2			
Pre-formed panels		C2			C2S1/S2	
Liquid-applied waterproofing products NON-CEMENT (CM)		given the variety of situations, follow the manufacturer's instructions				
Liquid-applied waterproofing products CEMENT (CM)		C2	C2		C2	
Pre-existing substrates with organic adhesive residues (with cementitious adhesives ⁽¹⁾)		C2	C2		C2S1/S2	
Pre-existing tiles/ mosaic/ stones		C2	C2		C2	
Pre-existing metal surfaces		R1-R2				

LEGEND	adhesive signs	provide adhesives or systems that guarantee full bed (e.g. double-spreading)
		size the joints according to the elastic modulus of the sealant and the lattice of the expansion joints
		laying excluded unless otherwise prescribed

ADHESIVES

Adhesives requirements (Class according to UNI EN 12004)						
Target environment:	Screed references (Strength class according to UNI EN 13813 or equal performance)	Tiles - Water absorption (according to UNI EN 14411) and Length of the longer side (cm)				
FLOORING COMMERCIAL INTERIOR		AA≤3% and AA>3%				
FLOORING INDUSTRIAL INTERIOR		≤30	≤60	≤90	≤120	>120
Substrate type (see table 3)	Cementitious screed without heating	C40 F6	C2		C2-C2S1/S2	
	Cast-in-place concrete		C2		C2	
	Pre-cast concrete		C2	C2-C2S1/S2		
	Liquid-applied waterproofing products CEMENT (CM)		C2	C2		C2
	Pre-existing substrates with organic adhesive residues ⁽¹⁾		C2		C2S1/S2	
	Pre-existing tiles/ mosaic/stones		C2		C2	
	Pre-existing metal surfaces		R1-R2	R1-R2	R1-R2	

Adhesives requirements (Class according to UNI EN 12004)						
Target environment:	Screed references (Strength class according to UNI EN 13813 or equal performance)	Tiles - Water absorption (according to UNI EN 14411) and Length of the longer side (cm)				
OUTDOOR RESIDENTIAL FLOORING		AA≤3% and AA>3%				
OUTDOOR PUBLIC FLOORING OUTDOOR FLOORING COMMERCIAL/INDUSTRIAL		≤30	≤60	≤90	≤120	>120
Substrate type (see table 3)	Cementitious screed without heating	C40 F6	C2		C2-C2S1/S2	
	Cast-in-place concrete		C2		C2-C2S1/S2	
	Pre-cast concrete		C2	C2-C2S1/S2		
	Liquid-applied waterproofing products CEMENT (CM)		C2	C2		C2
	Pre-existing tiles/ mosaic/stones		C2		C2	
	Pre-existing metal surfaces		R1-R2			

LEGEND	adhesive signs	provide adhesives or systems that guarantee full bed (e.g. double-spreading)
		size the joints according to the elastic modulus of the sealant and the lattice of the expansion joints
		laying excluded unless otherwise prescribed



OUR BRANCHES

GREECE:

ADRIA HELLAS LTD
KEFALLINIAS, 4
65300 KAVALA – GREECE
Tel./Fax: 0030-2510-225454
Mobile 0030-694-4640058
adriahellas.warehouse@gmail.com

TURKEY:

ADRIA ABRASIV LTD. STI
ASO 2. OSB. 2014. CADDE NO:34
ESKISEHIR YOLU, SINCAN
06930 ANKARA - TÜRKIYE
Tel.: 0090-312-2195557
Fax: 0090-312-2195728
Mobile 0090-541-7639202
adriaturkiye@abrasiviadria.com

SPAIN:

ADRIA ABRASIVOS S.L. CALLE C
POL. IND. A. GRANXA
PARALLELA 1 PARCELA 180
36475 PORRIÑO (PONTEVEDRA) - ESPAÑA
Tel.: 0034-986-344440
Fax: 0034-986-344715
info@adriaabrasivos.es

POLAND:

ADRIA POLSKA SP. Z.O.O.
UL. DURCOWA N. 15
58-150 STRZEGOM – POLAND
Mobile 0048-663928396
administracja@adriapolska.pl

USA:

ADRIA U.S.A. INC.
535 MILWAUKEE WAY
KNOXVILLE, TN, 37932
Mob. 001-201 471 1305
greg.palatnik@abrasiviadria.com

BRAZIL

ADRIA BRASIL IMPORTÇÃO
E EXPORTAÇÃO LTDA
TALMA RODRIGUES
RIBEIRO, 7456, SET II
LOT 01E02 GALPAO 1,
CIVIT II -29168080
SERRA - ES - BRAZIL
Tel./Fax: 0055-27-32185558
Mobile 0055-27-981430333
alex@adriabrasil.com

CANADA:

ADRIA CHEMICALS & ABRASIVES INC.
910 ROWNTREE DAIRY ROAD 8
L4L5W4 VAUGHAN - ONTARIO
Mobile.: +1 (437)7703525
jagtar.singh@abrasiviadria.com

www.kedil.eu



VERONA OFFICE:
Abrasivi Adria S.r.L. - Via dell'Industria, 63
37015 Sant'Ambrogio Valpolicella (VR) ITALY
Tel. +39 045 686 1311 - info@kedil.eu

SASSUOLO BRANCH:
Via Valle d'Aosta, 13
41049 Sassuolo (MO) ITALY